

ETI-Elettindustria srl

EQUIPAGGIAMENTO TRASFORMATORI ITALIA

T: +39 0245475074 | F: +39 0245475787

E-mail: cobETI@eti-elettindustria.it

Website: www.eti-elettindustria.it

Flow Indicators

Series CCL2

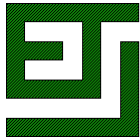

1 General Features

1.1 Characteristics

The liquid circulation indicators Series CCL2 are designed to detect the operation of circulation pumps in cooling installations, in particular those of electric transformers, and are therefore particularly suited for detecting the flow of oil or water in piping, respectively by types CCL2-O, for oil, and CCL2-A, for water. The possibility of using them with other fluids and/or in other installations depends on the fluid and its compatibility with the materials used in the construction of the device and must therefore be looked into in every case.

The presence of circulation is displayed optically by white and red indicators visible through two sight glasses and electrically by one or two electrical switches. The devices Series CCL2 only show that the liquid velocity inside the piping has the required value; **therefore the optical display may not be proportional to the velocity.**

The way the devices Series CCL2 work is based on the dynamic pressure applied by the moving fluid on detection disc paddle placed inside the pipe, whose dimensions depend on the diameter of the pipe itself and the flow rate that it will have to detect. An adjustment screw allows the triggering point to be altered, within certain limits, in order to adapt it to the effective local flow conditions.

1.2 Field of Use

The circulation indicators Series CCL2 may be used with the following characteristic values:

- | | |
|----------------------------|------------------------|
| • pipeline diameter | from 50 to 400 mm |
| • flow velocity | from 0,3 to 5,0 m/sec |
| • pressure in the pipe | from 0,0 to 2,0 bar |
| • working temperature | from -20°C to +120°C |
| • resistance to vibrations | up to 3 g on all axes |
| • resistance to shock | up to 10 g on all axes |

2 Special Features

Based on the experience of previous series, the design includes the following features, aimed at simplifying the choice of the device and its interchangeability, and allowing the user to modify the setting to a certain degree to allow for local flow conditions:

- two sight glasses placed perpendicularly to the direction of flow allow the optical display to be seen from both sides of the pipe and two cable entries, allow the electrical connection to be made from whichever side is most convenient; therefore the same device may be fitted indifferently with the flow from the left or from the right, provided the arrow engraved laterally on the flange points in the direction of the flow;
- the tension in the return spring is adjustable after removing the top cover, even with the device mounted in the pipe; this allows the indicator to be adjusted to the real working conditions.
- the devices made for mounting in vertical piping are provided with a counterweight fitted to the lever activating the optical and electrical displays in order to counterbalance the weight of the paddle; all of the devices may be fitted with this counterweight, which may be added as needed.

It is necessary to point out that the devices are supplied ready to be mounted according to the information given in the order and that any successive modification must be understood as exceptional.

Furthermore it is also necessary to inform us of these modifications, quoting the serial number of the article, so that we can update our records as regard any future supply of spare-parts.

3 Construction Features, Finish and Accessories

3.1 Construction Features

With reference to drawings N° 12.202.00 and N° 12.202.000 and the relative part description, which also indicates the materials, the device is constructed as follows:

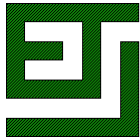

- on one side of the body 1.0 there is the flange 1.0.1 for assembly to the pipe with the gasket seat; on the other side body 1.0 is connected to casing 2.0; in order to avoid errors during assembly two arrows engraved on the body 1.0 indicate the direction of flow;
- on the side facing the pipe, the flow detector paddle 3.1, which can rotate by about 22° around the shaft 3.1.1, is fitted to the body 1.0; through the pin 3.2.1 the paddle 3.1 causes the transmission shaft 3.2 to rotate; the rotation of shaft 3.2 and of the paddle 3.1 is limited by the stops 3.2.2; the protection 1.1 protects these parts from damage during transportation and mounting;
- shaft 3.2 passes through the body 1.0 and activates the optical and electrical display by means of lever 3.3, fitted to the shaft itself; the sealing along the shaft 3.2 is assured by gaskets;
- the optical display consists of two red and white dials 3.3.1 fitted to lever 3.3 and visible through the sight glasses 2.2; the electric signal takes place through 1 or 2 microswitches 3.4 fixed to the body 1.0 and triggered by the lever 3.3;
- the electrical connection with the microswitches and the earth screw 3.8 can be made through the terminal 3.7 and the cable entries 2.0.1 by removing the casing cover 2.1; on the inside of cover 2.1 plate 2.4 shows the wiring diagram and the serial number; cable 2.5 ties the cover 2.1 to the casing 2.0, preventing it from getting lost or swapped;
- spring 3.5 returns the lever 3.3 and therefore also the paddle 3.1 to their rest position; through device 3.6 it is possible to adjust the tension of the spring 3.5 to adapt the detection to the local flow conditions.

As a special execution the liquid circulation indicators Series CCL2 can be supplied with the mounting dimensions according to drawing N° 12.202.70

3.2 Finish

In standard execution, all cast parts are protected by one coat of two-pack epoxy primer and one coat of two-pack polyurethane paint, final colour RAL 7031 and screws and washer are in stainless steel; the protection level of the device is IP 55 and of the contacts IP 67. Therefore the device is suitable for fitting in the open even in tropical climate and with high industrial pollution.

3.3 Accessories

The device is supplied with its assembly gasket and with one cable entry fitted with a metallic plug.

4 Wiring Diagrams and Contact Performance

As mentioned above, the circulation indicators Series CCL2 can be supplied with one or two electric contacts, set out according to one of the wiring diagrams shown in the specification N° 12SCHRxx, which indicates also the numbering of the terminals and the performance of the contacts.

As shown in specification contacts suitable for electronic circuits having low current (1 to 100 mA) and voltage (4 to 10 V) can also be supplied.

5 Operation

The circulation indicators Series CCL2 operate as follows:

- the fluid moving in the pipe hits the paddle 3.1, which has dimensions chosen according to pipe diameter and nominal fluid velocity, and causes it to rotate around its axis 3.1.1 by about 22°; the movement of the paddle is limited by the stops 3.2.2, which act on the pin 3.2.1;
- the movement of the paddle provokes the rotation of the shaft 3.2 by means of the pin 3.2.1, winning over the force of the return spring 3.5;
- lever 3.3 triggers the electric signal through microswitches 3.7 while the two red and white displays 3.3.1, fitted to the lever itself, move in front of the sight glasses 2.2, showing either the red or white sector, respectively when the flow rate is lower or higher than the pre-set value; as already mentioned, the optical display may not be proportional to the flow rate;
- when the fluid velocity falls below the pre-set value, the return spring 3.5 brings the mechanism into its rest position.

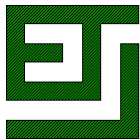

6 Mounting, Adjustment and Maintenance

6.1 Mounting

The circulation indicators Series CCL2 may be used when the working conditions are within the values indicated in chapter 1.2.

The device is either mounted on a flange with stub pipe, welded directly to the pipe following the dimensions indicated in the table of the assembly example of drawing N° 12.300.00, or by mounting a flanged stub pipe onto the pipeline, sectioned off by valves, and attaching the device to it as indicated in the assembly drawing N° 12.300.00. It is best to choose this second method if the device will need to be removed for maintenance, as may be necessary if it is used with water.

The device is mounted using 4 bolts, with the insertion of the assembly gasket supplied with the device. After attaching it to the pipe, carry out the electrical connection according to the chosen wiring diagram through the terminal board 3.7, accessible after removing the cover 2.1. After mounting, verify that the optical and electric indicators are working correctly by starting up and stopping the pump.

In order to make sure the signal paddle 3.1 is hit by the most uniform possible flow, avoid mounting the device immediately down stream of bends, necks or other parts which could cause turbulence in the flow; if this is impossible, the adjustment of the tension in the return spring 3.5, allows the indicator to be set to the real flow conditions

6.2 Adjustment

The device is always supplied set according to the information given at ordering and with the adjustment spring 3.5 loaded to about half the maximum load, so that it is possible to both increase the load, so the device is triggered at a higher flow rate, or decrease the load, with the opposite effect. To make adjustments of spring 3.5 proceed as follows:

- remove cover 2.1;
- insert a hollow barrel spanner inside on the hexagonal adjuster 3.6;
- insert a screwdriver in the barrel spanner and unscrew the adjustment locking screw one turn;
- turn the hexagonal adjuster in anticlockwise direction to increase the operational flow rate and in clockwise direction to decrease it; the maximum angle the hexagonal adjuster can be rotated is about 90°; two lockpins prevent it from being turned beyond this angle;
- lock the hexagon 3.6 in the new position by tightening the locking screw;
- verify that the device is working correctly by starting up and stopping the circulation pump.
- replace cover 2.1.

6.3 Maintenance

The circulation indicators Series CCL2 do not need regular maintenance, however it is advisable to check that they are working correctly at regular intervals by starting up and stopping the circulation pump and verifying that the optical and electrical display takes place as normal.

As mentioned above, it is possible that if used with water deposits and encrustation's may form which prevent the device from working correctly. In this case remove the device from the pipe - closing any shutoff valves present or emptying the installation - and carry out cleaning by removing protection 1.1 and eliminate the encrustation's mechanically until the paddle moves freely once again.

7 Order Specifications

When ordering it is necessary to indicate the following data:

- type of device:
 - ◊ CCL2-O for use with transformer oil;
 - ◊ CCL2-A for use with water;
- pipeline diameter;
- mounting position according to one of the diagrams in drawing N° 12.202.00;
- flow rate at which the indicator should be triggered;
- wiring diagram according to specification N° 12SCHxx;
- thread of cable entry.



Specification N°

Product:

Page N°

12SCHR02-E**Flow Indicators Series CCL2 and SCFR2****1 of 2**

Title:

Revision N°

Performance of contacts and description of wiring diagrams**02 – 12.06.06****1 Performance of the contacts and description of the wiring diagrams**

The specification has a complete description of the contacts and of performance and function of the wiring diagrams.

2 Wiring diagrams**2.1 Identification by numbering of the wiring diagrams**

The identification numbering of the wiring diagrams follows criteria that allow to identify type of contacts and operation of the wiring diagram from it's number.

2.1.1 Key to numbering of wiring diagrams

The following numbering system applies to wiring diagrams with standard contacts; wiring diagrams with low current contacts are considered special and have a separate numbering.

12-xxx = Wiring diagram for flow indicators;

12-Xxx = Total number of contacts:

1, 2, 3 and 4 = 1, 2, 3 or 4 contacts

12-xXx = Contact Type

0 = Normally open; **1** = Normally closed; **3 or 9** = Changeover

12-xxX = Contacts position:

1 = Contact/s for minimum flow; **2** = Contact/s for maximum flow;

3 = One contact for minimum + one contact for maximum flow

4 to 9 = Other positions

2.2 Table of Contact's Performance**2.2.1 Standard Contact (ST)**

Changeover microswitch contact worked mechanically

Degree of protection

IP 67

Casing

Poliester

Gasket

Fluorosilicon rubber

Lever and push button

Stainless steel

Contact's material

Silver, nickel coated

Mechanical endurance of contact

1x10⁷ cycles

Temperature range

-40°C to +125°C

Standard power of interruption (1x10⁵ cycles)

AC 250V/5A - DC 125V/1A

Maximum power of interruption (1.000 cycles)

DC 125V/1,5A

Isolation to mass at 20°C

2.500 V

Isolation of open contact at 20°C

1.500 V

Minimum and maximum current

0,1 - 10A

2.2.2 Low Current Contact (BC)

Same performance as standard contact except:

Contact's material

Gold

Operation range

1 to 100 mA - 4 to 30 V

2.2.3 Electric circuitry

Degree of protection of instrument casing:

- Type CCL2

IP 65

- Type SCFR2

IP 55

Insulation to mass

2.500 V

Material of terminal board

tin coated brass

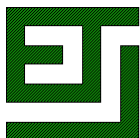

Specification N°

12SCHR02-E

Product:

Flow Indicators Series CCL2 and SCFR2

Page N°

2 of 2

Title:

Performance of contacts and description of wiring diagrams

Revision N°

02 – 12.06.06

3 Tables of function and performance o wiring diagrams

The most commonly used wiring diagrams are described in detail in the following tables; the following notes describe the acronyms.

3.1 Notes on tables of function and performance of wiring diagrams

The following tables showing the performance of the wiring diagrams make use of some acronyms; for a full understanding they are explained in the following:

NE = Normal exercise = corresponds to maximum flow

N° Term. = Numbers that identify the terminals

N° WD = Wiring diagram number

Pos. in NE = State of the contact in normal exercise.

3.2 Tabella

N° WD	N° Term.	Pos. in NE	Functional description of wiring diagram	Operates at
12-000			Without contacts, only optical indication	
12-131	1-2	Open	1 changeover contact for minimum flow	minimum
	1-3	Closed		
12-132	1-2	Open	1 changeover contact for maximum flow	maximum
	1-3	Closed		
12-291	1-2/4-5	Open	2 changeover contacts for minimum flow	minimum
	1-3/4-6	Closed		
12-292	1-2/4-5	Open	2 changeover contacts for maximum flow	maximum
	1-3/4-6	Closed		
12-293	1-2	Open	1 changeover contact for minimum flow	minimum
	1-3	Closed		
	4-5	Open	1 changeover contact for maximum flow	maximum
	4-6	Closed		



Nomenclature N°

Reference drawing N°

Page N°

12CCL2NomR01-E**12.202.00 - 12.202.70 - 12.202.000****1 of 1**

Product:

Revision N°

Oil and Water Flow Indicators Series CCL2**01 of 04.06.06**

Pos.	Part Denomination	N°	Material
1.0	Body with flow direction indication	1	CCL2-O - Aluminium
			CCL2-A - Brass
1.0.1	Mounting flange	1	
	Types CCL2-O and CCL2-A with O-Ring gasket seat for OR 6262		
	Types CCL2-OS and CCL2-AS without gasket seat		
1.1	Protection	1	Brass
2.0	Casing	1	Aluminium
2.0.1	Cable entry - Max 1" or PG21	2	
2.1	Casing cover	1	Aluminium
2.2	Window of optical indication	2	Acrylic
2.3	Window frame	2	Nylon 30% glass fibre
2.4	Wiring diagram and serial number plate	1	Aluminium
2.5	Cover fixing string	1	Nylon
3.0	Optical and electrical indication unit		
3.1	Flow measuring disk paddle	1	CCL2-O - Aluminium
			CCL2-A - Brass
3.1.1	Paddle shaft	1	Stainless steel
3.2	Transmission shaft	1	Stainless steel
3.2.1	Transmission shaft 3.2 driving pin	1	Stainless steel
3.2.2	Transmission shaft 3.2 stop pins	2	Stainless steel
3.3	Lever of optical and electrical indication	1	Brass
3.3.1	Dials of optical indication	2	Aluminium serigraph
3.4	Microswitches	1/2	
3.5	Reset spring	1	Spring steel
3.6	Regulation knob	1	Brass
3.7	Terminal board for electrical connection	1	
3.8	Earthing screw	1	Stainless steel

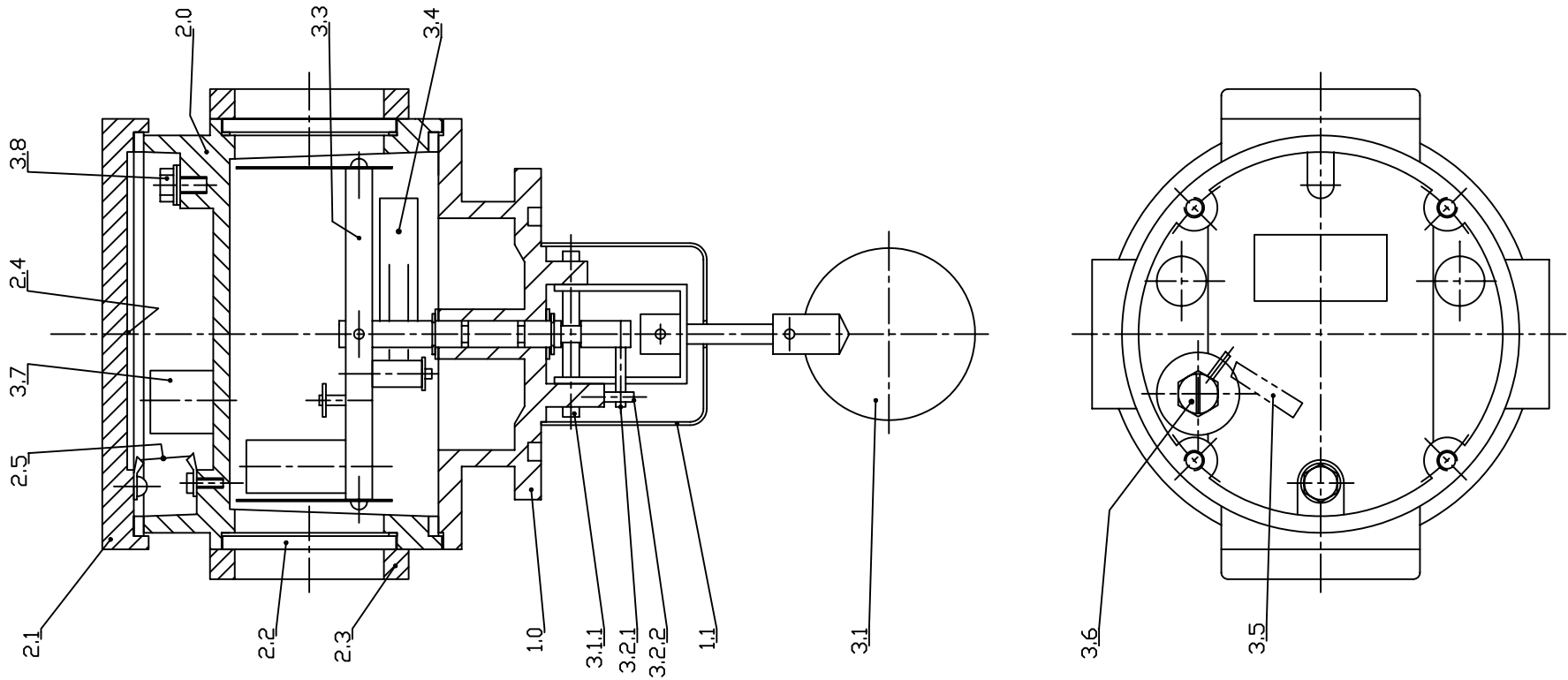

N.rev	Nota sulla revisione	Data	Signatura	Controllo
-------	----------------------	------	-----------	-----------

Rif.	Quantità	Titolo/Nome, designazione, materiale, dimensione, etc.			N. articolo/Riferimento	
Progettato da	Controllato da	Approvato da - data	Nome file	Data	20-04-99	Scala //
 ETI ELETTRINDUSTRIA Srl 20032 CORMANO ITALY			Titolo/Nome CCL-2 Sezione - Section		Numero disegno 12.202.000	Modifici Foglio
Riproduzione vietata Non misurate le quote dal disegno						

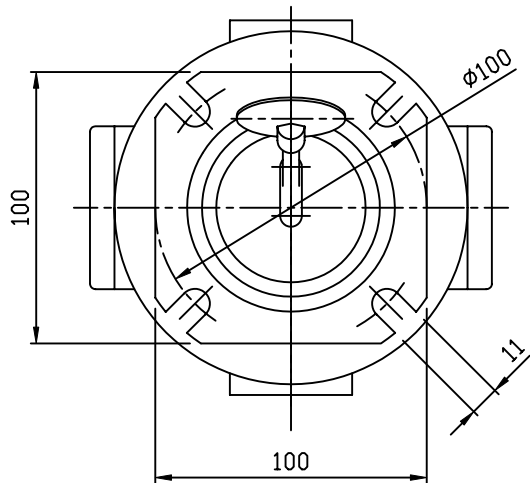

Schema di montaggio
 Assembly exemple
 Schéma de montage

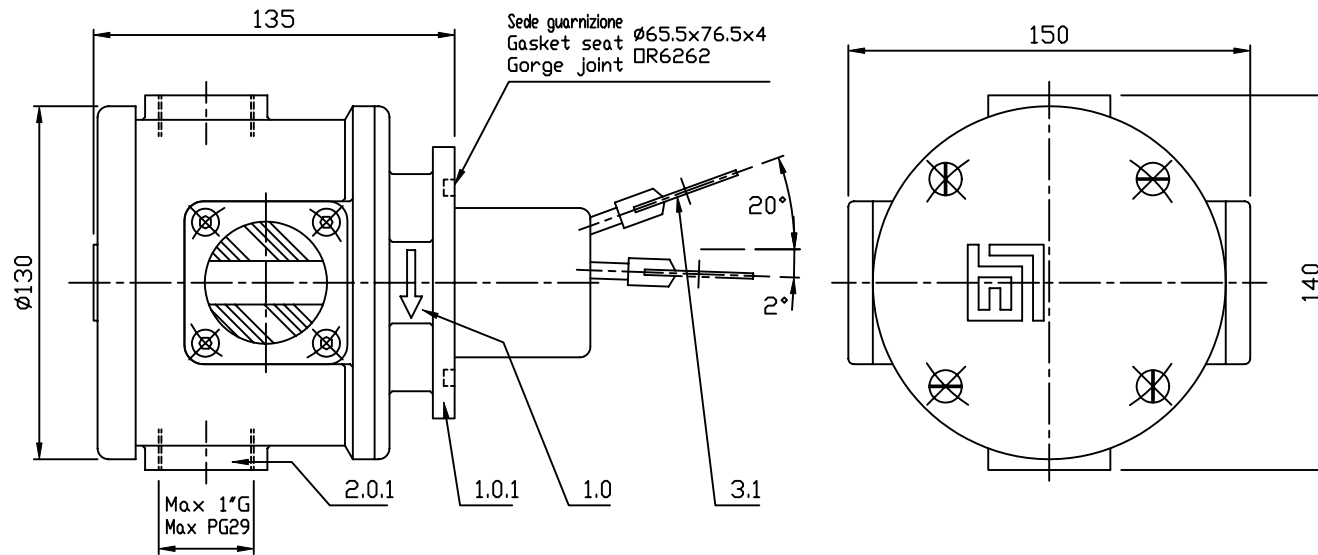

Posizione di montaggio
 Mounting position
 Position de montage

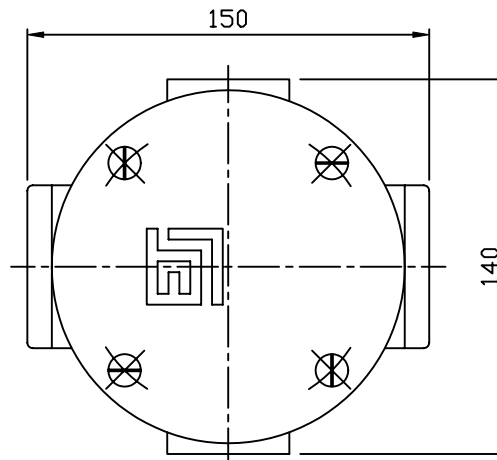

Pos.	DN	H
1	50	90
2	65	
3	80	
4	100	
5	125	115
6	150	
7	175	140
8	200	
9	250	165
10	300	195

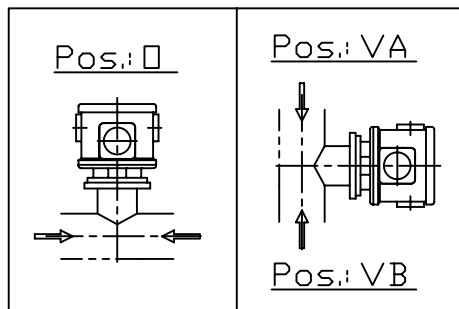
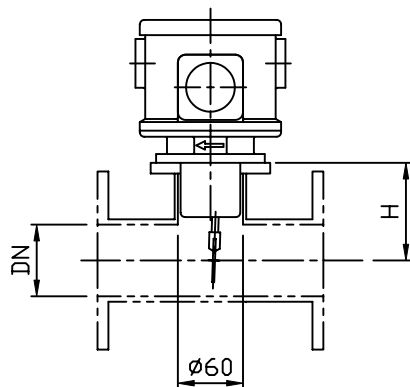

Rif.	Quantità	Titolo/Nome, designazione, materiale, dimensione, etc.			N. articolo/Riferimento	
Progettato da	Controllato da	Approvato da - data	Nome file	Data	Scala	
				19-04-99	//	
ETI ELETTRINDUSTRIA S.p.A. 20032 CORMANO ITALY			Titolo/Nome Segnalatore di circolazione - Circulation indicator - Indicateur de circulation Serie: CCL-2 / □ / A		Numero disegno	Modificae
			12.202.00			Foglio
Riproduzione vietata Non misurare le quote dal disegno						

N.rev	Nota sulla revisione	Data	Signatura	Controllo

Esecuzione speciale solo per ricambi
 Special execution for exchange purposes only
 Execution spéciale seulement pour rechange

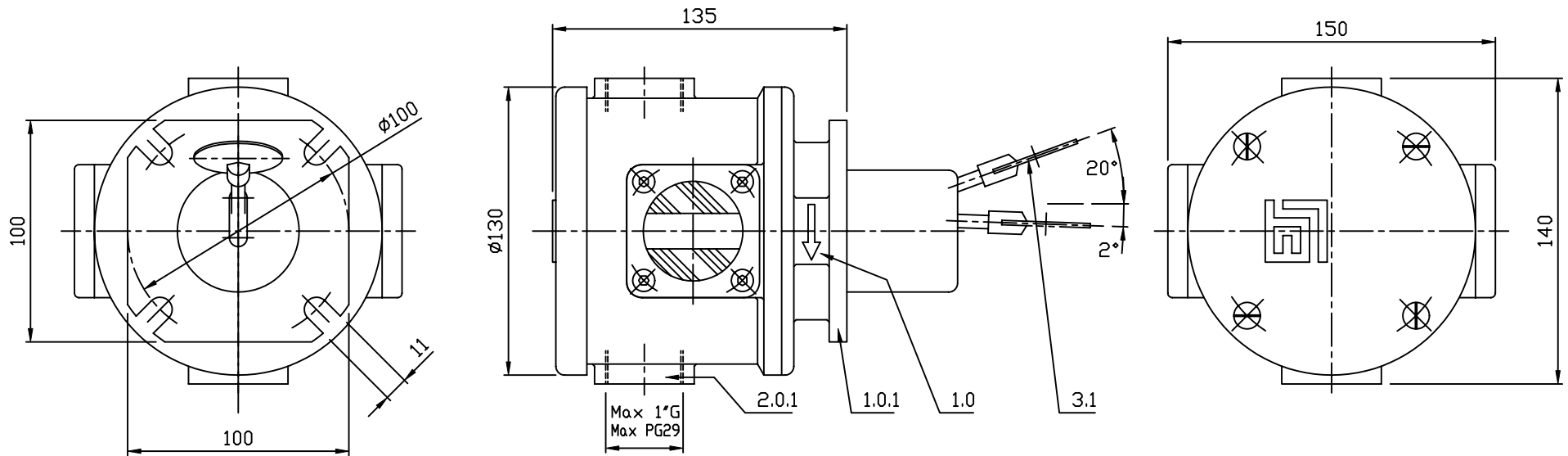

Schema di montaggio
 Assembly exemple
 Schéma de montage

Posizione di montaggio
 Mounting position
 Position de montage

Pos.	DN	H
1	50	90
2	65	
3	80	
4	100	
5	125	115
6	150	
7	175	140
8	200	
9	250	165
10	300	195

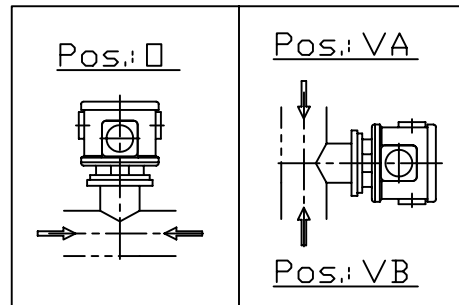
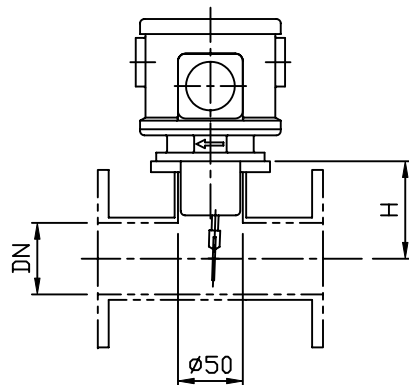

Ref.	Quantità	Titolo/Nome, designazione, materiale, dimensione, etc.			N. articolo/Riferimento	
Progettato da	Controlato da	Approvato da - data	Nome file	Data	Scale	
				19-04-99	//	
ETI ELETTRINDUSTRIA S.p.A. 20032 CORMANO ITALY			Titolo/Nome Segnalatore di circolazione - Circulation indicator - Indicateur de circulation Serie: CCL2-DS - CCL2-AS		Numero disegno	Modifica
			12.202.70			Foglio
Riproduzione vietata			Non misurate le quote dal disegno			

N.rev	Nota sulla revisione	Data	Signatura	Controllo