



ETI-Elettindustria Srl.

Via Fabio Filzi, 65 - 20032 - Cormano Italy

Tel. +390266306518 - +390266303250

Fax. +390266300174

E-mail: cobETI@edimail.bnl.it

Flow Indicators Series CCL2

Catalogue N°: 12CCL2CATR01-E

Revision: 01 of 20.11.2001



ETI-Elettrindustria Srl.

Via Fabio Filzi, 65 - 20032 - Cormano Italy

Tel. +390266306518 - +390266303250

Fax. +390266300174

E-mail: cobETI@edimail.bnl.it

Catalogue N° 12CCL2CATR00-E

Rev. N° 00 - 08.06.2000

12 – Oil and Water Flow Indicators Series CCL2

Page N° 1 of 4

1 General Features

1.1 Characteristics

The liquid circulation indicators Series CCL2 are designed to detect the operation of circulation pumps in cooling installations, in particular those of electric transformers, and are therefore particularly suited for detecting the flow of oil or water in piping, respectively by types CCL2-O, for oil, and CCL2-A, for water. The possibility of using them with other fluids and/or in other installations depends on the fluid and its compatibility with the materials used in the construction of the device and must therefore be looked into in every case.

The presence of circulation is displayed optically by white and red indicators visible through two sight glasses and electrically by one or two electrical switches. The devices Series CCL2 only show that the liquid velocity inside the piping has the required value; **therefore the optical display may not be proportional to the velocity.**

The way the devices Series CCL2 work is based on the dynamic pressure applied by the moving fluid on detection disc paddle placed inside the pipe, whose dimensions depend on the diameter of the pipe itself and the flow rate that it will have to detect. An adjustment screw allows the triggering point to be altered, within certain limits, in order to adapt it to the effective local flow conditions.

1.2 Field of Use

The circulation indicators Series CCL2 may be used with the following characteristic values:

- pipeline diameter from 50 to 400 mm
- flow velocity from 0,3 to 5,0 m/sec
- pressure in the pipe from 0,0 to 2,0 bar
- working temperature from -20°C to +120°C
- resistance to vibrations up to 3 g on all axes
- resistance to shock up to 10 g on all axes

2 Special Features

Based on the experience of previous series, the design includes the following features, aimed at simplifying the choice of the device and its interchangeability, and allowing the user to modify the setting to a certain degree to allow for local flow conditions:

- two sight glasses placed perpendicularly to the direction of flow allow the optical display to be seen from both sides of the pipe and two cable entries, allow the electrical connection to be made from whichever side is most convenient; therefore the same device may be fitted indifferently with the flow from the left or from the right, provided the arrow engraved laterally on the flange points in the direction of the flow;
- the paddle along with its support shaft may be easily replaced after having removed the transmission mechanism protection; therefore it is possible to use the same device on pipes of different diameter and with different flow rates, by replacing the paddle and the shaft;
- even if only one contact is requested, all the devices may have a second contact fitted which can be added when needed; wiring diagrams may be supplied that cover all possible needs of the customer;
- the tension in the return spring is adjustable after removing the top cover, even with the device mounted in the pipe; this allows the indicator to be adjusted to the real working conditions.
- the devices made for mounting in vertical piping are provided with a counterweight fitted to the lever activating the optical and electrical displays in order to counterbalance the weight of the paddle; all of the devices may be fitted with this counterweight, which may be added as needed.

It is necessary to point out that the devices are supplied ready to be mounted according to the information given in the order and that any possible modifications afterward must be understood as exceptional operations.

Furthermore it is also necessary to inform us of these modifications, quoting the serial number of the article, so that we can update our records as regard any future supply of spare-parts.



3 Construction Features, Finish and Accessories

3.1 Construction Features

With reference to drawings N° 12.202.00 and N° 12.202.000 and the relative part description, which also indicates the materials, the device is constructed as follows:

- on one side of the body 1.0 there is the flange 1.0.1 for assembly to the pipe with the gasket seat; on the other side body 1.0 is connected to casing 2.0; in order to avoid errors during assembly two arrows engraved on the body 1.0 indicate the direction of flow;
- on the side facing the pipe, the flow detector paddle 3.1, which can rotate by about 22° around the shaft 3.1.1, is fitted to the body 1.0; through the pin 3.2.1 the paddle 3.1 causes the signal transmission shaft 3.2 to rotate; the rotation of shaft 3.2 and therefore of the paddle 3.1 is limited by the stops 3.2.2; the protection 1.1 protects these parts from damage during transportation and mounting;
- shaft 3.2 passes through the body 1.0 and activates the optical and electrical display by means of lever 3.3, fitted to the shaft itself; the sealing along the shaft 3.2 is assured by gaskets;
- the optical display consists of two red and white dials 3.3.1 fitted to lever 3.3 and visible through the sight glasses 2.2; the electric signal takes place through 1 or 2 microswitches 3.4 fixed to the body 1.0 and triggered by the lever 3.3;
- the electrical connection with the microswitches and the earth screw 3.8 can be made through the terminal 3.7 and the cable entries 2.0.1 by removing the casing cover 2.1; on the inside of cover 2.1 plate 2.4 shows the wiring diagram and the serial number; cable 2.5 ties the cover 2.1 to the casing 2.0, preventing it from getting lost or swapped;
- spring 3.5 returns the lever 3.3 and therefore also the paddle 3.1 to their rest position; through device 3.6 it is possible to adjust the tension of the spring 3.5 to adapt the detection to the local flow conditions.

3.2 Finish

In standard execution, all cast parts are protected by one coat of two-pack epoxy primer and one coat of two-pack polyurethane paint, final colour RAL 7031 and screws and washer are in stainless steel; the protection level of the device is IP 55 and of the contacts IP 67. Therefore the device is suitable for fitting in the open even in tropical climate and with high industrial pollution. Special versions are available for particularly severe climatic and/or aggressive atmospheric conditions.

3.3 Accessories

The device is supplied with its assembly gasket and with one cable entry fitted with a plug and the other with a cable gland.

4 Wiring Diagrams and Contact Performance

4.1 Wiring Diagrams

As mentioned above, the circulation indicators Series CCL2 can be supplied with one or two electric contacts, set out according to one of the wiring diagrams shown in the specification N° 12SCHRx, which indicates also the numbering of the terminals.

4.2 Contacts Performance

Specification N° 12SCHxx shows also the performance of the contacts; special contacts for electronic circuits having low current (1 to 100 mA) and voltage (4 to 10 V) can also be supplied.



5 Operation

The circulation indicators Series CCL2 operate as follows:

- the fluid moving in the pipe hits the paddle 3.1, which has dimensions chosen according to pipe diameter and nominal fluid velocity, and causes it to rotate around its axis 3.1.1 by about 22°; the movement of the paddle is limited by the stops 3.2.2, which act on the pin 3.2.1;
- the movement of the paddle provokes the rotation of the shaft 3.2 by means of the pin 3.2.1, winning over the force of the return spring 3.5;
- lever 3.3 triggers the electric signal through microswitches 3.7 while the two red and white displays 3.3.1, fitted to the lever itself, move in front of the sight glasses 2.2, showing either the red or white sector, respectively when the flow rate is lower or higher than the pre-set value; as already mentioned, the optical display may not be proportional to the flow rate;
- when the fluid velocity falls below the pre-set value, the return spring 3.5 brings the mechanism into its rest position.

6 Mounting, Adjustment and Maintenance

6.1 Mounting

The circulation indicators Series CCL2 may be used when the working conditions are within the values indicated in chapter 1.2.

The device is either mounted on a flange with stub pipe, welded directly to the pipe following the dimensions indicated in the table of the assembly example of drawing N° 12.300.00, or by mounting a flanged stub pipe onto the pipeline, sectioned off by valves, and attaching the device to it as indicated in the assembly example of drawing N° 12.300.00. It is best to choose this second method if the device will need to be removed for maintenance, as may be necessary if it is used with water. On request both the flange to be welded to the pipe and the connecting stub pipe with the relative valves can be supplied.

The device is mounted using 4 bolts, with the insertion of the assembly gasket supplied with the device. After attaching it to the pipe, carry out the electrical connection according to the chosen wiring diagram through the terminal board 3.7, accessible after removing the cover 2.1. After mounting, verify that the optical and electric indicators are working correctly by starting up and stopping the circulation pump.

In order to make sure the signal paddle 3.1 is hit by the most uniform possible flow, avoid mounting the device immediately down stream of bends, necks or other parts which could cause turbulence in the flow; if this is impossible, the adjustment of the tension in the return spring 3.5, allows the indicator to be set to the real flow conditions

6.2 Adjustment

The device is always supplied set according to the information given at ordering and with the adjustment spring 3.5 loaded to about half the maximum load, so that it is possible to both increase the load, so the device is triggered at a higher flow rate, or decrease the load, with the opposite effect. To make adjustments of spring 3.5 proceed as follows:

- remove cover 2.1;
- insert a hollow barrel spanner inside on the hexagonal adjuster 3.6;
- insert a screwdriver inside the barrel spanner and unscrew the adjustment locking screw by about one turn;
- turn the hexagonal adjuster in anticlockwise direction to increase the operational flow rate and in clockwise direction to decrease it; the maximum angle the hexagonal adjuster can be rotated is about 90°; two lockpins prevent it from being turned beyond this angle;
- lock the hexagon 3.6 in the new position by tightening the locking screw;
- verify that the device is working correctly by starting up and stopping the circulation pump.
- replace cover 2.1.



ETI-Elettrindustria Srl.

Via Fabio Filzi, 65 - 20032 - Cormano Italy

Tel. +390266306518 - +390266303250

Fax. +390266300174

E-mail: cobETI@edimail.bnl.it

Catalogue N° 12CCL2CATR00-E

Rev. N° 00 - 08.06.2000

12 – Oil and Water Flow Indicators Series CCL2

Page N° 4 of 4

6.3 Maintenance

The circulation indicators Series CCL2 do not need regular maintenance, however it is advisable to check that they are working correctly at regular intervals by starting up and stopping the circulation pump and verifying that the optical and electrical display takes place as normal.

As mentioned above, it is possible that if used with water deposits and encrustation's may form which prevent the device from working correctly. In this case remove the device from the pipe - closing any shutoff valves present or emptying the installation - and carry out cleaning by removing protection 1.1 and eliminate the encrustation's mechanically until the paddle moves freely once again.

7 Order Specifications

- When ordering it is necessary to indicate the following data:
- type of device:
 - ◊ CCL2-O for use with transformer oil;
 - ◊ CCL2-A for use with water;
- pipeline diameter;
- mounting position according to one of the diagrams in drawing N° 12.202.00;
- flow rate at which the indicator should be triggered;
- wiring diagram according to specification N° 12SCHxx;
- thread of cable entry.



Specification N° **SPR/**

12SCHR01-E

Product:

Flow Indicators Series CCL2 and SCFR2

Page N°

2 of 2

Title:

Performance and description of wiring diagrams

Revision N°

01 - 20.11.01

3 Tables of function and performance o wiring diagrams

The most commonly used wiring diagrams are described in detail in the following tables; the following notes describe the acronyms.

3.1 Notes on tables of function and performance of wiring diagrams

The following tables showing the performance of the wiring diagrams make use of some acronyms; for a full understanding they are explained in the following:

NE = Normal exercise = corresponds to maximum flow

N° Term. = Numbers that identify the terminals

N° WD = Wiring diagram number

Pos. in NE = State of the contact in normal exercise.

3.2 Table

N° WD	N° Term.	Pos. in NE	Functional description of wiring diagram	Operates at
12-000			Without contacts, only optical indication	
12-131	1-2	Open	1 changeover contact for minimum flow	minimum
	1-3	Closed		
12-132	1-2	Open	1 changeover contact for maximum flow	maximum
	1-3	Closed		
12-291	1-2/4-5	Open	2 contacts for minimum flow	minimum
	1-3/4-6	Closed		
12-292	1-2/4-5	Open	2 contacts for maximum flow	maximum
	1-3/4-6	Closed		
12-293	1-2	Open	1 changeover contact for minimum flow	minimum
	1-3	Closed		
	4-5	Open	1 changeover contact for maximum flow	maximum
	4-6	Closed		



ETI-Elettrindustria Srl.

Via Fabio Filzi, 65 - 20032 - Cormano Italy

Tel. +390266306518 - +390266303250

Fax. +390266300174

E-mail: cobETI@edimail.bnl.it

Nomenclature N°

12CCL2-E

Reference drawing N°

12.202.00 - 12.202.70 - 12.202.000

Page N°

1 of 1

Product:

Oil and Water Flow Indicators Series CCL2

Revision N°

00 of 08.06.00

Pos.	Part denomination	N°	Material
1.0	Body with flow direction indication	1	CCL2-O - Aluminium CCL2-A - Brass
1.0.1	Mounting flange: Types CCL2-O and CCL2-A with O-Ring gasket groove for OR 6262 Types CCL2-OS and CCL2-AS without O-Ring gasket groove	1	
1.1	Protection	1	Brass
2.0	Casing	1	Aluminium
2.0.1	Cable entry - Max 1" or PG21	2	
2.1	Casing cover	1	Aluminium
2.2	Window of optical indication	2	Acrylic
2.3	Window frame	2	Nylon 30% glass fibre
2.4	Wiring diagram and serial number plate	1	Aluminium serigraph.
2.5	Cover fixing string	1	Nylon
3.0	Optical and electrical indication unit		
3.1	Flow measuring disk paddle	1	CCL2-O - Aluminium CCL2-A - Brass
3.1.1	Disk paddle axis	1	Stainless steel
3.2	Transmission shaft	1	Stainless steel
3.2.1	Transmission shaft pin	1	Stainless steel
3.2.2	Transmission shaft stops	2	Stainless steel
3.3	Lever of optical and electrical indication	1	Brass
3.3.1	Dials of optical indication	2	Aluminium serigraph.
3.4	Microswitches	1/2	
3.5	Reset spring	1	Spring steel
3.6	Regulation knob	1	Brass
3.7	Terminal board for electrical connection	1	
3.8	Earthing screw	1	Stainless steel

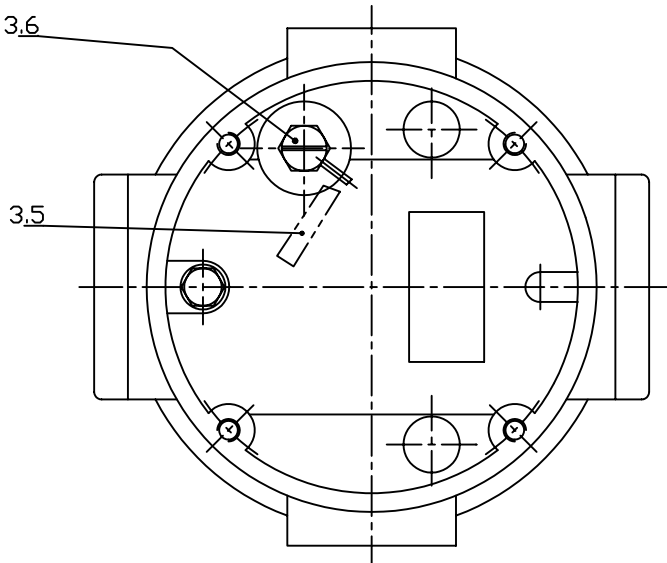
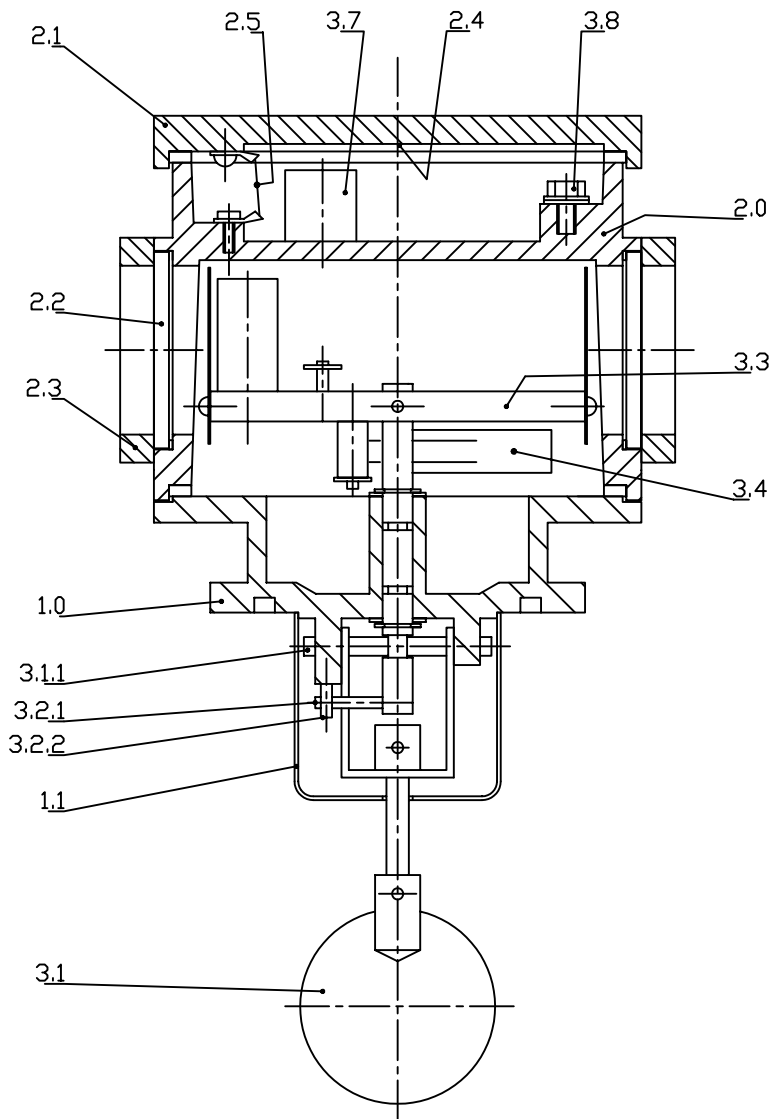

N:rev Nota sulla revisione Data Signatura Controllo

Aut. / Disegno	Titolo/Descrizione, materiale, dimensioni, ecc.	N. ordine/Revisione
Progettato da	Completato da	Approvato da - data
Disegnato da	Verificato da	Nome e data
20-04-99		
Scala		///



CCCL-2 Sezione - Section
 12.202.000

Riproduzione vietata Non misurare le quote dal disegno

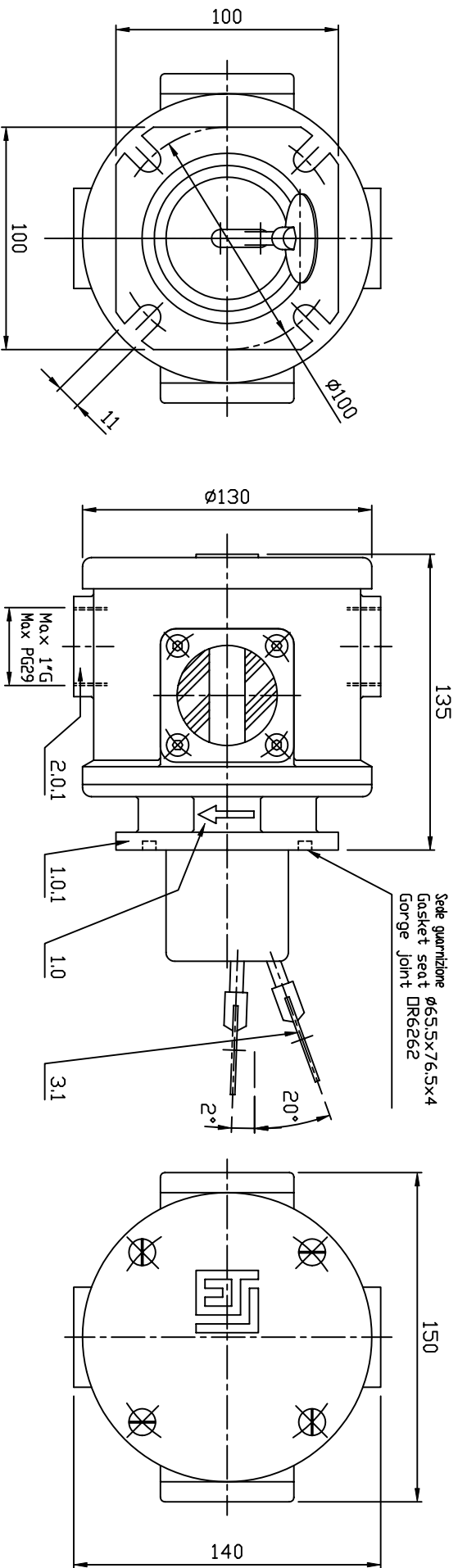

Schema di montaggio
 Assembly exemple
 Schéma de montage

Posizione di montaggio
 Mounting position
 Position de montage

Pos.	DN	H
1	50	
2	65	90
3	80	
4	100	
5	125	115
6	150	
7	175	140
8	200	
9	250	165
10	300	195

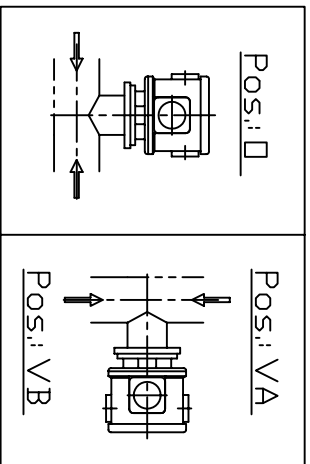
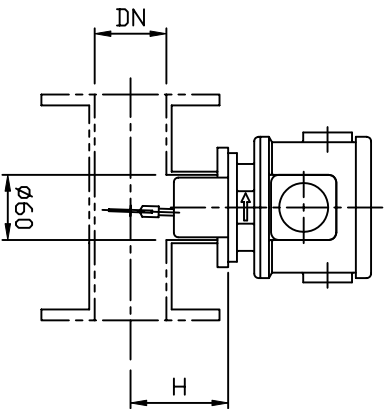

N./rev

Data

Nota sulla revisione

Signatura

Controllo

Ref.	Quantità	Descrizione, designazione, materiale, dimensioni, etc.	Requisiti	Approvato da - data	Nome	Titolo	Scadenza



ETI ELETTRINDUSTRIA S.p.A.
 20032 CORIMANO ITALY
 Separatore di circolazione - Circulation indicator - Indicateur de circulation
 Serie: CCL-2 / 0 / A
 Numero disegno: 12.202.00

Riproduzione vietata. Non misurare le quote dal disegno.

Esecuzione speciale solo per ricambi
 Special execution for exchange purposes only
 Execution spéciale seulement pour rechange

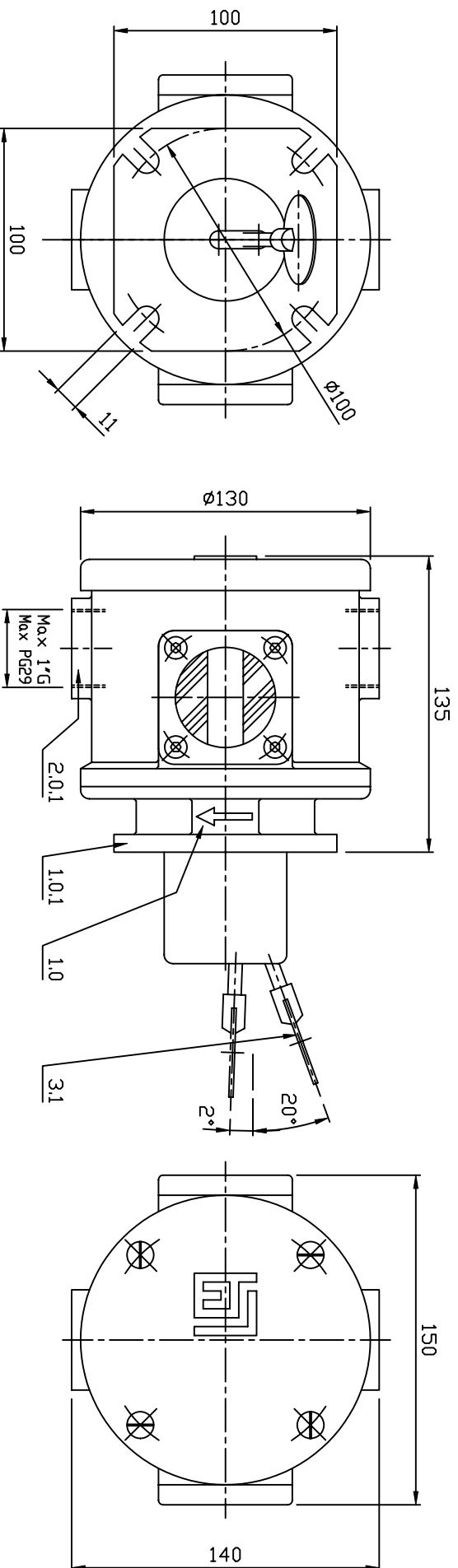

Schema di montaggio
 Assembly exemple
 Schéma de montage

Pos.	DN	H
1	50	
2	65	90
3	80	
4	100	
5	125	115
6	150	
7	175	140
8	200	
9	250	165
10	300	195

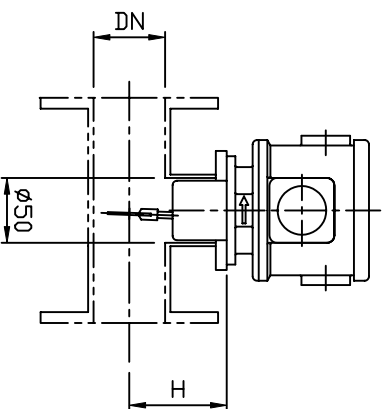

Posizione di montaggio
 Mounting position
 Position de montage

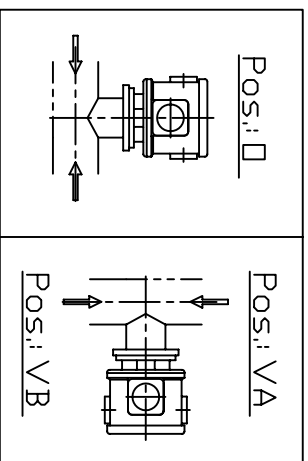

N. rev Nota sulla revisione

Data

Signature Controllo

Tit.	Quantità	Tipico/Numero, designazione, materiale, dimensioni, etc.	N. articolo/Intestazione	Scala
Progettato da		Completato da	Approvato da - data	19-04-99
				//



Tipico/Numero
 Segnalatore di circolazione - Circulation Indicator - Indicateur de circulation
 Serie: CCL2-DS - CCL2-AS
 Numero disegno
 12.202.70

Riproduzione vietata Non misurare le quote dal disegno