

ETI-Elettindustria srl

EQUIPAGGIAMENTO TRASFORMATORI ITALIA

T: +39 0245475074 | F: +39 0245475787

E-mail: cobETI@eti-elettindustria.it

Website: www.eti-elettindustria.it

Pressure Relief Valves Series VS - VST

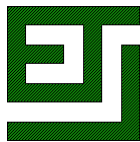

Specification N°

10VSGENR04-E

Accessory:

Pressure relief valve Series VS - VST

Page N°:

1 of 5

Title:

Function, features, operation and assembly

Revision:

04 – 08/2009

1.0 Contents of specification

The specification concerns the function, the main features and the operation of the pressure relief valves Series VS and VST, as well as the admitted environmental and operating condition for the different executions. Operating conditions depend generally from the compatibility of the materials, components, surface finish, and, for the electric contacts and circuits, their degree of protection, with the operating conditions of the transformer.

2.0 Function

The pressure relief valves Series VS and VST open when the pressure inside the transformer's tank increases over the set operating value, following for example a failure or a short circuit, and by releasing oil reduces the pressure in the tank. By means of the electric contact, if present, and the optical indication the pressure relief valve indicates that a fault has taken place.

The pressure relief valves Series VST have been specially designed for use on transformers where an oil spillage is absolutely to be avoided; typical installation are on trains or ships or where environmental or safety standard are particularly exacting.

The oil-tight cover contains the oil released by the valve when opening and provides a flanged connection on which a pipe can be attached that ducts the oil in the desired direction

3.0 Construction features

3.1.0 Materials and components

- Flange, obturator, cover and electric contact's casing are of cast aluminium;
- Fittings are of stainless steel or nickel coated brass;
- Gasket materials as specified for the different executions;
- Splash diverter of Series VS is made of stainless steel;
- Springs are of spring steel, sandblasted and painted with epoxy powders;
- External screws are of stainless steel.

3.2.0 Reference drawings

Overall dimensions:

Pressure relief valves Series VS with contact type K

- Type VSQI 050 NKP - nominal diameter 50 mm N° 10.050.710
- Type VS 080 NKP - nominal diameter 80 mm N° 10.080.90
- Type VS 100 NKP - nominal diameter 100 mm N° 10.100.90
- Type VS 150 NKP - nominal diameter 150 mm N° 10.150.90

Pressure relief valves Series VS with contact type C

- Type VS 080 NCP - nominal diameter 80 mm N° 10.080.10
- Type VS 100 NCP - nominal diameter 100 mm N° 10.100.10
- Type VS 150 NCP - nominal diameter 150 mm N° 10.150.10

Pressure relief valves Series VS without contact

- Type VSQI 050 NP - nominal diameter 50 mm N° 10.050.705

Pressure relief valves Series VST with oil tight cover

- Type VST 080 - without electric contacts N° 10.080.80
- Type VST 080 K - with one or two electric contacts N° 10.080.70

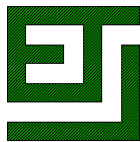

Specification N°

10VSGENR04-E

Accessory:

Pressure relief valve Series VS - VST

Page N°:

2 of 5

Title:

Function, features, operation and assembly

Revision:

04 – 08/2009

- Type VST 150 – with or without contacts N° 10.150.70
- Type VSQT 150 – with or without contacts N° 10.Q15.00
- Type VST 150 and VSQT 150 – section N° 10.Q15.10

The drawings show the valves complete with splash diverter.

3.3.0 Construction

The pressure relief valves Series VS and VST are spring operated safety valves, consisting of a mounting flange with the central opening closed by a spring loaded obturator; the springs are compressed between obturator and cover (Series VS) or obturator and pressure ring (Series VST), which is assembled to the flange by columns.

No part of the pressure relief valve reaches inside the transformer tank. A specially designed gasket assures the oil-tightness between flange and obturator when the valve is closed.

The oil-tight cover of Series VST encases the valve completely and provides the flanged connection on which a pipe can be attached.

3.4.0 Pressure setting and springs

The setting of the pressure relief valves Series VS and VST is effected by choosing a different spring - for valve diameter 150 mm a double spring set – for every operating pressure value; therefore the setting of the pressure relief valve can be changed only at the factory, thus eliminating possible misuses.

The springs are of the compression type, designed so as to have a low force gain with the stroke.

Specification N° 10VSTARRxx indicates the tolerance of the setting and the minimum operating pressure for the different pressure settings as well as the minimum pressure at which the valve closes after operation. To avoid oil leakage or undue operation of the valve, the operating pressure must be chosen so that in normal operation the corresponding maximum operating pressure is never reached.

3.5.0 Operation indicators

3.5.1.0 Optical indicator

The pressure relief valves Series VS and VST have as a standard feature an optical indicator showing that the valve has operated; the optical indicator consists of a red pin showing about 30 mm over the top of the valve cover when the valve has operated because of an internal overpressure. The pin is spring loaded so that even after a partial opening of the valve due to limited or short-duration overpressures the pin is nevertheless expelled completely.

For Types VSQI 050, VST 150 and VSQT 150 the optical indication operates also the electric contact, if present.

3.5.2.0 Electric contact

The operation of the pressure relief valve can be indicated also by electric contact, which can be of the “C” type, according to specification N° 10VSSCHCRxx or of the “K” type according to specification N° 10VSSCHKRxx.

3.6.0 Splash diverter

To avoid that during the operation of the valve hot oil is shot in all directions, thus increasing the danger to man and machine, the valves Series VS can be fitted with a splash diverter, which diverts the out-flowing oil in a determined direction.

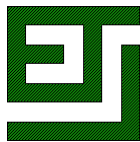

Specification N°

10VSGENR04-E

Accessory:

Pressure relief valve Series VS - VST

Page N°:

3 of 5

Title:

Function, features, operation and assembly

Revision:

04 – 08/2009

3.7.0 Oil-tightness and resistance to pressure

The pressure relief valves Series VS and VST:

- are oil tight to oil at 100°C up to pressure P_t , which depends on the setting pressure;
- are mechanically and electrically resistant to vacuum (10 torr);
- have a mechanical resistance to pressures up to 4 bars.

3.8.0 Resistance to dynamical stress

The pressure relief valves Series VS can operate without undue operation in following conditions:

- Sinus vibrations with frequency ≤ 120 Hz and amplitude $\leq 250 \mu$;
- Dynamical conditions causing following accelerations:
 - ◇ Max 3g in all directions, sinus vibration, amplitude ≤ 20 mm;
 - ◇ Shock condition with max 10 g in all directions.

3.9.0 Surface protection

Flange, obturator, cover and contact's casing are painted internally and externally with one primer coat of epoxy paint and externally with a finishing coat of polyurethane paint colour RAL 7031. The primer coat on the internal surfaces in contact is compatible with transformer mineral oil up to temperatures of 120°C.

The painting procedure is accepted by the Italian electricity authority ENEL.

The specification N° 00VERRxx describes in details all the features of the painting procedure relevant to the protection against corrosion.

4.0 Operation and installation

4.1.0 Operation

Should an overpressure inside the transformer tank build up due to short circuit or else, higher than the set operation pressure of the pressure relief valve, the obturator lifts from the flange propelled by the pressure, thus opening the discharge opening. The oil can flow out thus reducing the overpressure; at the same time the optical indication and if installed the electric contact show that the valve has operated. When the overpressure has been discharged the valve shuts again automatically to complete oil-tightness.

With the valves Series VST the oil discharged remains inside the oil-tight cover and can be ducted to an appropriate container by a pipe flanged to the cover.

Thanks to the design of the pressure relief valves and their springs, the full opening is reached even for small overpressures in a very short time, so as to reduce immediately the resistance to the oil flow.

4.2.0 Importance of the electric contact

Real life tests have shown that failures of the transformer followed by sudden pressure increases, such as for instance short circuits, induce the operation of the pressure relief valve in time spans which are considerably shorter than that of other safety devices, such as the Buchholz Relay. **To exploit this rapid operation for the safety of the transformer we strongly advice to fit out the pressure relief valve with electric contacts, which should be connected to the trip circuit of the transformer.**

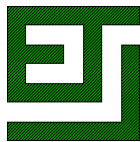

Specification N°

10VSGENR04-E

Accessory:

Pressure relief valve Series VS - VST

Page N°:

4 of 5

Title:

Function, features, operation and assembly

Revision:

04 – 08/2009

4.3.0 Installation

The pressure relief valve should be installed, either in horizontal or vertical position, on the transformer tank, as near as possible to possible failure sources or in a central position to such sources. The size of the pressure relief valve should be chosen considering the available space and the oil quantity to be vented in case of failure.

For a higher safety standard and to increase the rapidity of operation it can be preferable to install more than one pressure relief valve eventually of a smaller size.

4.4.0 Choice of nominal pressure

To avoid oil leakage or undue operation of the valve, the operating pressure should be chosen so that in normal operation the corresponding maximum operating pressure is never reached. Furthermore, to reduce oil loss after operation, the minimum pressure at which the valve closes after operation should be always higher than the oil head insisting on the valve.

5.0 Compatibility

The installation compatibility of the pressure relief valves Series VS and VST depend mainly on the material used for the gaskets; therefore the executions differ because of the used gaskets.

5.1.0 Standard execution – nitrile rubber gaskets (N)

Admitted operating conditions are:

Environmental conditions:

Ambient temperature

-20°C to +50°C

Relative humidity

95% to 20°C - 80% to 40°C - 50% to 50°C

Insulating liquid: transformer mineral or silicon oil

Temperature

- 20°C to + 110°C

5.2.0 Execution Nf - nitrile rubber gaskets for low temperatures (Nf)

Admitted operating conditions are:

Environmental conditions:

Ambient temperature

-40°C to +50°C

Relative humidity

95% to 20°C - 80% to 40°C - 50% to 50°C

Insulating liquid: transformer mineral or silicon oil

Temperature

- 40°C to + 120°C

5.3.0 Execution V – Fluor rubber gaskets (Viton V)

Admitted operating conditions are:

Environmental conditions:

Ambient temperature

-15°C to +50°C

Relative humidity

95% to 20°C - 80% to 40°C - 50% to 50°C

Insulating liquid: transformer mineral or silicon oil

Temperature

- 15°C to + 150°C

5.4.0 Special executions

For other environmental and/or operating conditions to be examined individually.

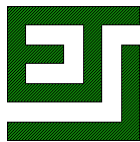

Specification N°

Accessory:

Page N°:

10VSGENR04-E**Pressure relief valve Series VS - VST****5 of 5**

Title:

Revision:

Function, features, operation and assembly**04 – 08/2009**

6.0 Identification of types

Taking for example pressure relief valve Type **VS 080 NCP 0,5**, which indicates:

- pressure relief valve series VS;
- nominal diameter 80 mm;
- with nitrile rubber gaskets N;
- with one contact type C;
- with splash diverter P
- with operating pressure 0,5 bars,

the pressure relief valves Series VS are identified as follows:

VS	080	N	C	P	0,5
Series identification:					
VS	Pressure relief valve Series VS, types VS 080, VS 100, VS 150				
VSQI	Only for pressure relief valve type VSQI 050				
VST	Pressure relief valve Series VST, types VST 080, VST 150				
VSQT	Only for pressure relief valve type VSQT 150				
Identification of nominal diameter:					
050	Nominal diameter 50 mm				
080	Nominal diameter 80 mm				
100	Nominal diameter 100 mm				
150	Nominal diameter 150 mm				
Identification of gasket type:					
N	Nitrile rubber gaskets				
Nf	Nitrile rubber gaskets for low temperatures				
V	Fluor rubber gaskets (Viton)				
Identification of contact – see contacts specifications					
...	Contact type ...				
Optional splash diverter:					
-	Without splash diverter or series VST valves				
P	With splash diverter				
Operating pressure:					
0,5	Operating pressure 0,5 bars				

7.0 Reference specifications

- Setting tolerance
- Wiring diagrams and contacts
Contacts type C
Contacts type K
- Painting

N° 10VSTARRxx

N° 10VSSCHCRxx

N° 10VSSCHKRxx

N° /00VERRxx

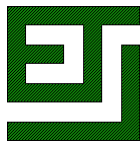

Specification N°

10VSSCHCR00-E

Accessory:

Pressure relief valve Series VS - VST

Page N°:

1 of 1

Title:

Features contact type C

Revision:

00 – 10/10/99

1.0 Features contact type C

The specification indicates the electrical and mechanical features as well as the admitted environmental conditions for the contact type C and its wiring.

2.0 Resetting of the contact

In standard execution the contact resets automatically when the valve closes after the overpressure is discharged. On request the contact can be supplied with manual reset and in this case the resetting of the contact after operation is obtained by acting on the spring that hooks the lever in the operating position.

3.0 Features

The contact type C is a mechanically operated sudden operation changeover microswitch with double interruption bedded in a protecting casing; it can have one or two contacts and the construction is usually Telemecanique.

- Telemecanique – one contact type ZCK-J1
- Telemecanique – two contacts type ZCK-J2
- Degree of protection IP 66
- Standard cable gland PG 13,5
- Cable gland on request M20
- Resistance to vibrations (IEC 68-2-6) 25g from 10 to 500 Hz
- Resistance to shock 50g
- Protection against electric shocks Class I according to IEC 536
- Contact resistance ≤ 25 mOhms
- Standard interruption power (1×10^5 operations) AC 250V-3,5A - 24V-10A
DC 24V-10W - 120V-4W
- Short life interruption power (100 operations) DC 120V-150W
- Insulation to earth at 20°C 2.500V
- Insulation of open contact at 20°C 1.500V

4.0 Table of function and operation of contact

Wiring diagram N°	Terminal N°	Contact's position in NE	Description of wiring diagram
10-131C	13-14	Open	1 changeover contact, trips with overpressure; name of wiring diagram on type label = C
	21-22	Closed	
10-291C	14-13/23-24	Open	2 changeover contacts, trip with overpressure; name of wiring diagram on type label = 2C
	11-12/21-22	Closed	

Two contacts having the same function may not operate simultaneously.

If the contact is of the manual reset type, the letter **m** is added to the contact's name on the type label.

Notes:

NE = Normal operation; the pressure in the tank is lower than the setting pressure of the valve:

Wiring diagram N° = Identification number of the wiring diagram

Terminal N° = Identification of the terminals by numbers

Contact's position in NE = State of the contact in normal operation.

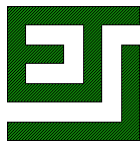

Specification N°

Accessory:

Page N°:

10VSSCHKR01-E**Pressure relief valve Series VS - VST****1 of 2**

Title:

Revision:

Features contact type K**01 – 06/10/02**

1.0 Features contact type K

The specification indicates the electrical and mechanical features as well as the admitted environmental conditions for the contact type K and it's wiring.

2.0 Resetting of the contact

In standard execution the contact must be reset manually after operation, when the valve closes after the overpressure is discharged, by acting on the hook that holds the lever in the operating position. By dismantling the hook, the contact resets automatically.

3.0 Features

The contact type K is a mechanically operated sudden operation changeover microswitch with one interruption; the microswitch is mounted inside an aluminium protecting case and the terminals are connected to a terminal board.

3.1.0 Standard contact (ST) - Crouzet type 83 169 4 or Matsushita

- Degree of protection IP 67
- Lever and pushbutton Stainless steel
- Contact material Nickel coated silver
- Mechanical endurance of contact 1×10^7 cycles
- Temperature range -40°C - +125°C
- Standard interruption power AC 250V-5A - DC 125V-1A
- Short endurance interruption power (100 cycle) DC 125V-1,5A
- Insulation to earth at 20°C 2.500V
- Insulation of open contact at 20°C 1.500V
- Minimum and maximum current 1,0 - 10A

3.2.0 Low current contact (BC) - Crouzet type 83 169 8

Contacts type BC are used only on request; features are identical to standard contact except for:

- Contact material Gold alloy
- Minimum and maximum current and voltage 1 to 100mA - 4 to 30V

3.3.0 Electric circuit

- Degree of protection of protective casing IP 65
- Material of casing Cast aluminium
- Insulation to earth at 20°C 2.500V
- Material of terminals tin coated brass

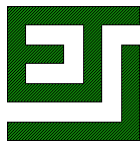

Specification N°

Accessory:

Page N°:

10VSSCHKR01-E

Pressure relief valve Series VS - VST

2 of 2

Title:

Revision:

Features contact type K

01 – 06/10/02

4.0 Table of function and operation of contact

Wiring diagram N°	Terminal N°	Contact's position in NE	Description of wiring diagram
10-131K	1-2	Open	1 changeover contact with manual reset, trips with overpressure; name of wiring diagram on type label = Km
	1-3	Closed	
10-291K	1-2 / 4-5	Open	2 changeover contacts with manual reset, trip with overpressure; name of wiring diagram on type label = 2Km
	1-3 / 4-6	Closed	

Two contacts having the same function may not operate simultaneously.

Notes:

NE = Normal operation; the pressure in the tank is lower than the setting pressure of the valve:

Wiring diagram N° = Identification number of the wiring diagram

Terminal N° = Identification of terminals by numbers

Contact's position in NE = State of the contact in normal operation.

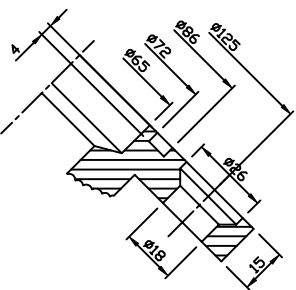
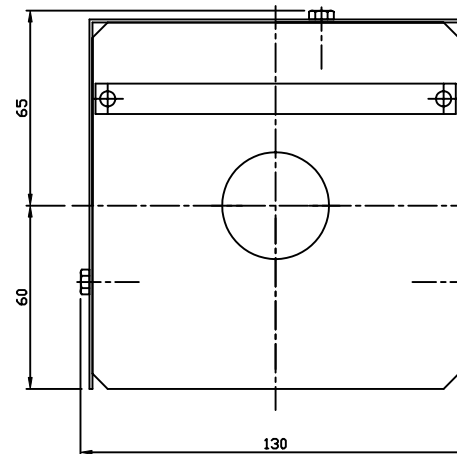
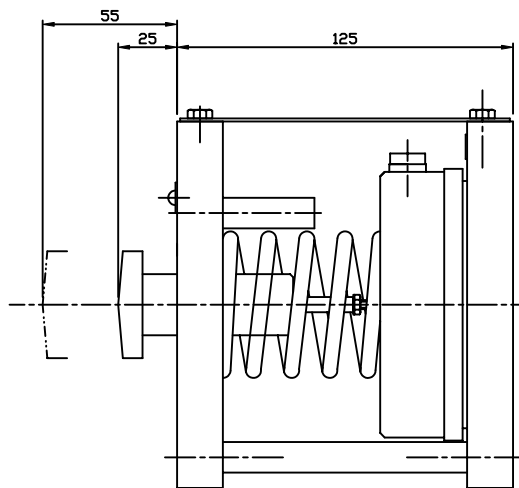
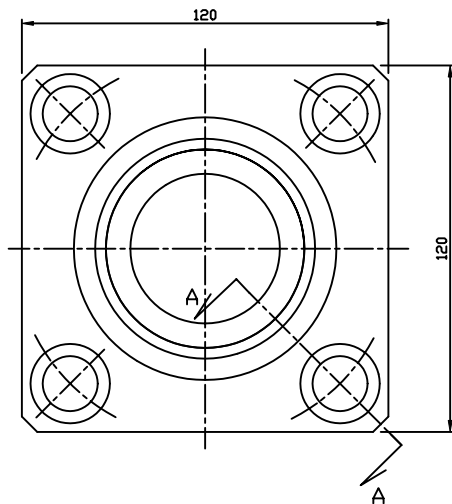

Sez.:A-A

A	Corretto \varnothing fori 18 era 16	06/03/02	GL	
N.rev	Nota sulla revisione	Data	Firma	Controllo

Rev.	Descriz.	Titolo/Firma, designazione, materiale, dimensioni, etc.	N. ordine / Modificato	
Preparato da	Controlato da	Approvato da - data	Nome file	Data 05/03/01
ELETRINDUSTRIA SRL 20032 CORMANO ITALY			Valvola di sicurezza Tipo - Type Safety valve VSA-I 050 P Soupape de securite	
Numero disegno 10.050.705			Sezione A	Foglio

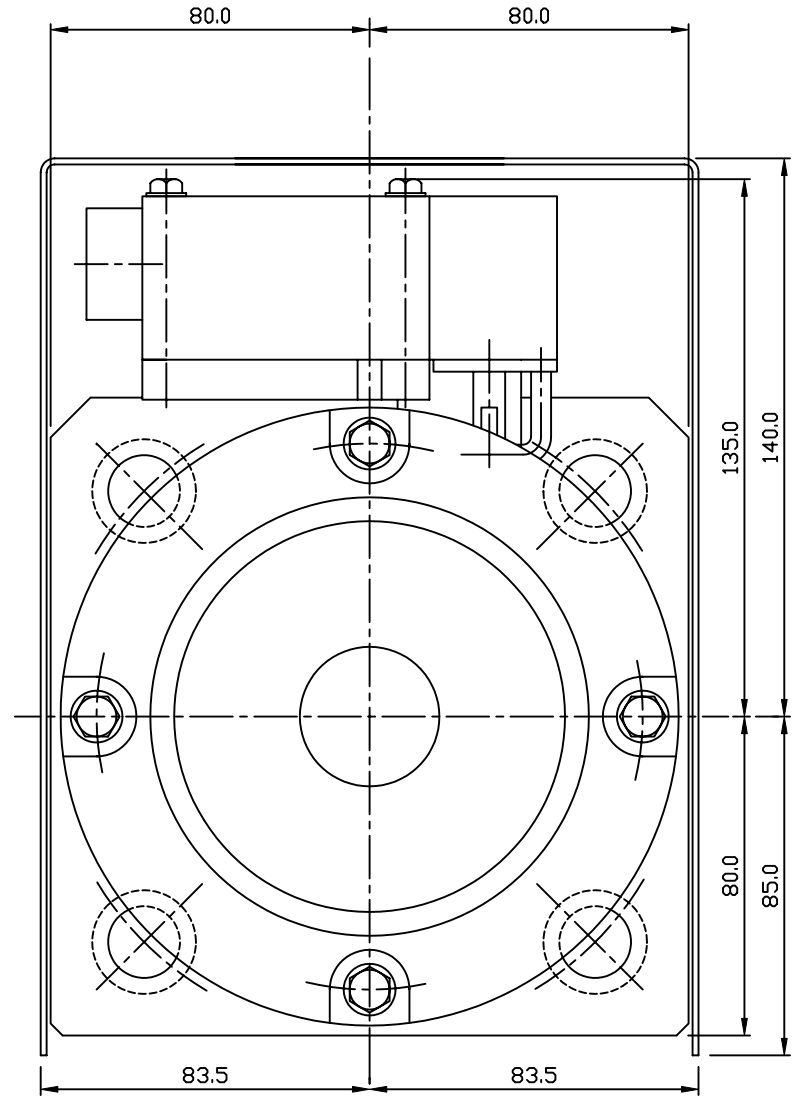
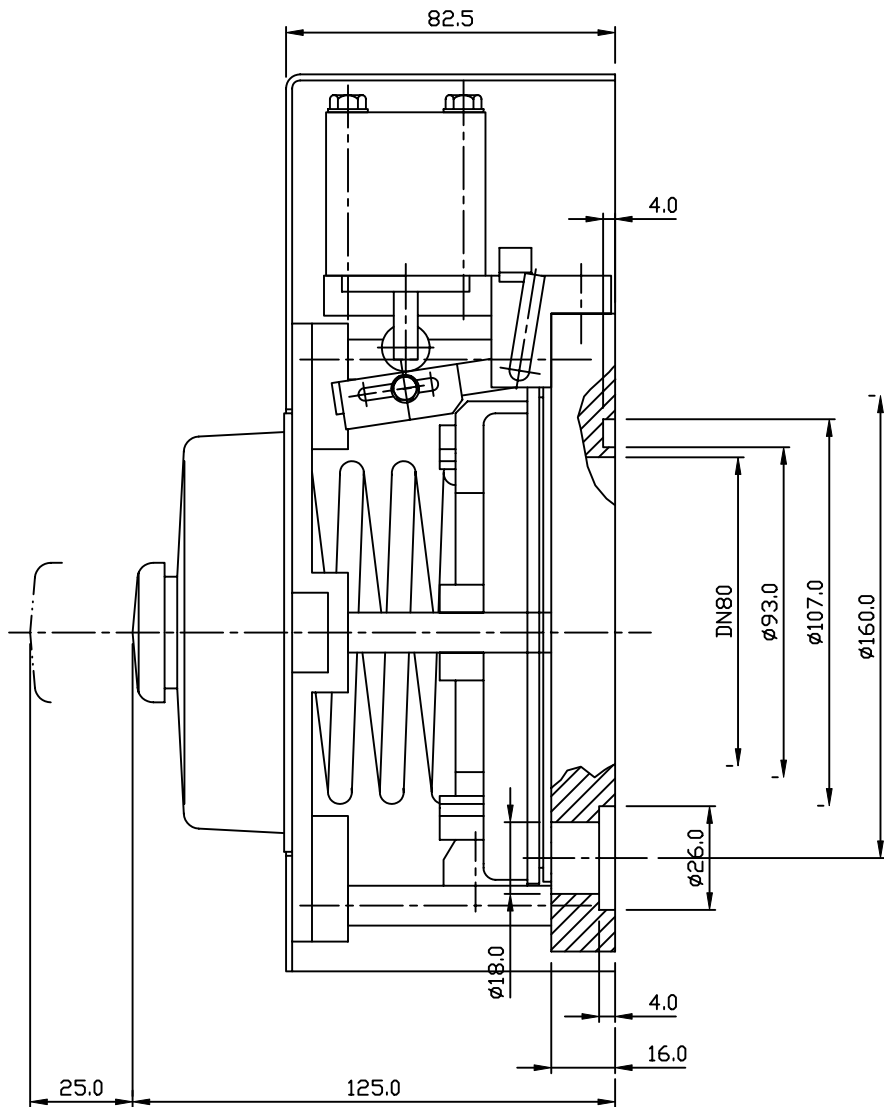

N.rev	Nota sulla revisione	Data	Signatura	Controllo
-------	----------------------	------	-----------	-----------

Rif.	Quantità	Titolo/Nome, designazione, materiale, dimensione, etc.			N. articolo/Riferimento	
Progettato da	Controlato da	Approvato da - data	Nome file	Data	Scala	
ETI ELETTRINDUSTRIA S.p.A. 20032 CORMANO ITALY			Titolo/Nome VALVOLA DI SICUREZZA - SIOUPEE DE SECURITE - SAFETY VALVE TIPO-TYPE VS080NCP		Numero disegno	Modifica
			10.080.10		Foglio	
Riproduzione vietata			Non misurare le quote dal disegno			

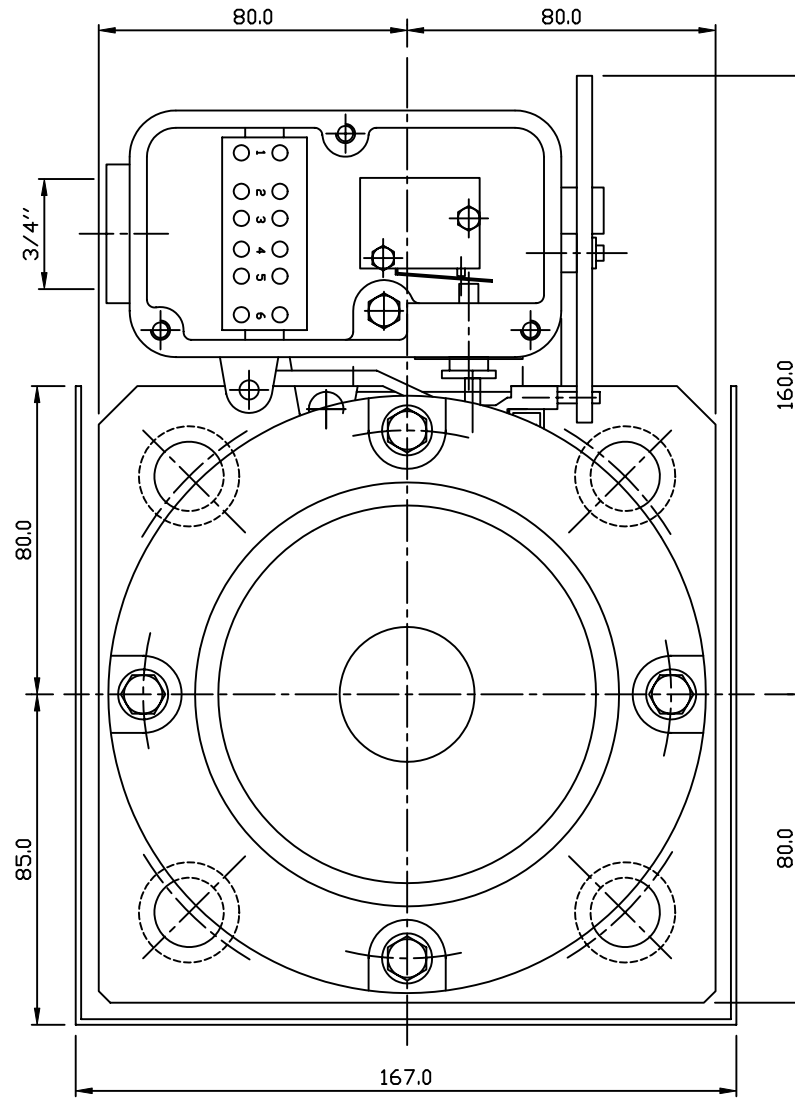
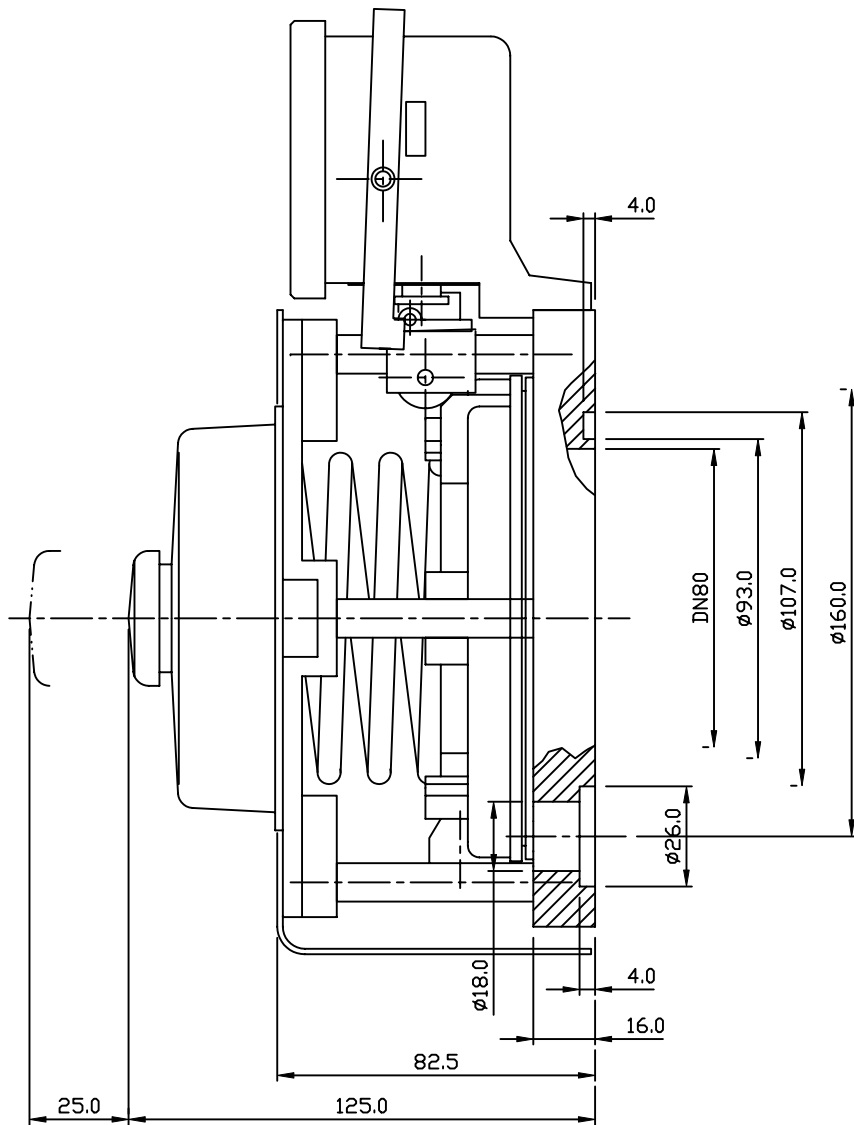

A	Modificata denominazione tipo	11-10-2001	GG	
N.rev	Nota sulla revisione	Data	Signatura	Controllo

Rif.	Quantità	Titolo/Nome, designazione, materiale, dimensione, etc.			N. articolo/Riferimento	
Progettato da	Controllato da	Approvato da - data	Nome file	Data	30-10-98	Scala 1:1
			Titolo/Nome VALVOLA DI SICUREZZA - SOUPEE DE SECURITE - SAFETY VALVE TIPO-TYPE VS 080 NKP			
			Numero disegno	10.080.90	Modifica	Foglio
Riproduzione vietata		Non misurate le quote dal disegno				

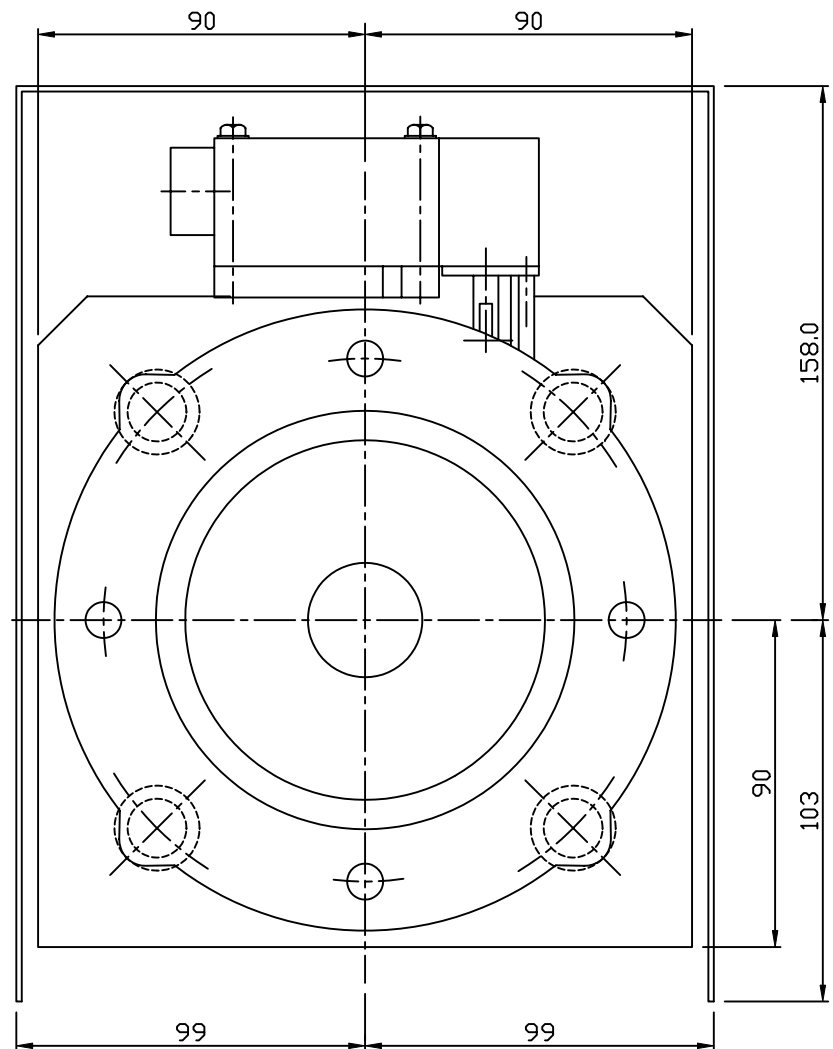
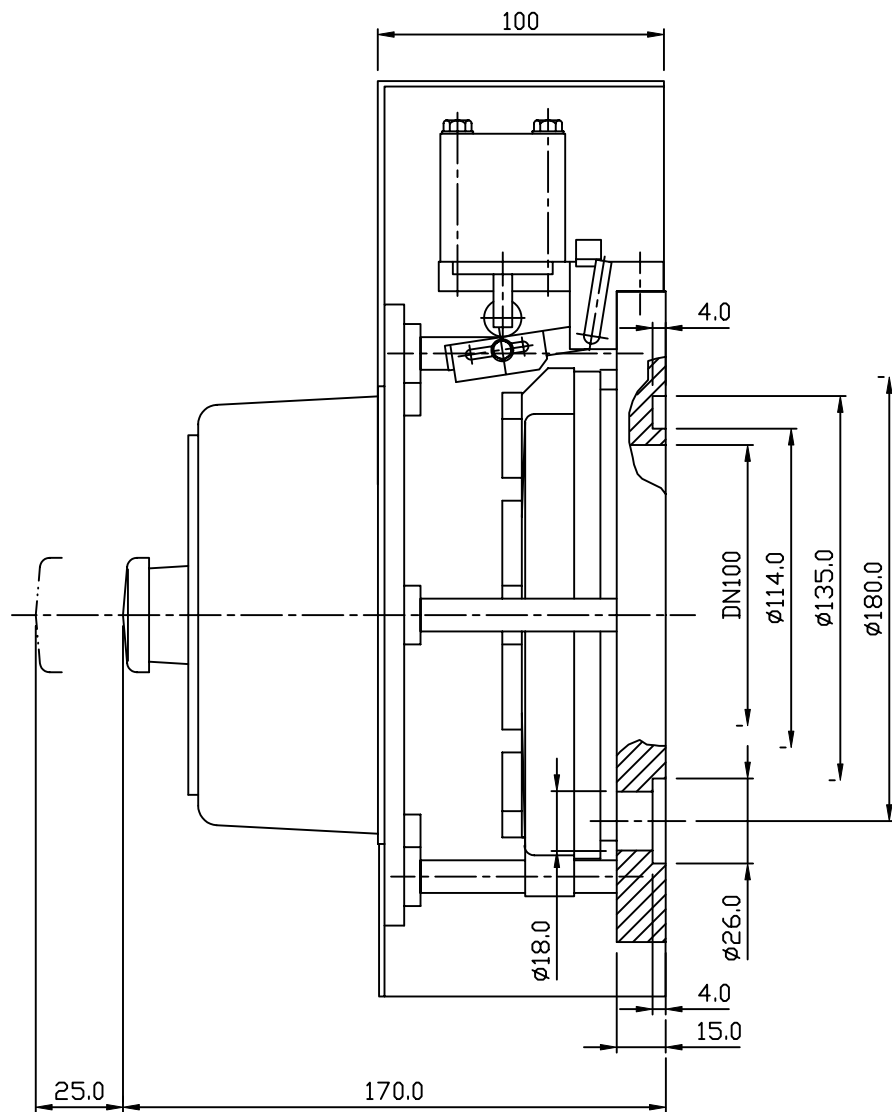

A	Aggiornato dimensioni flangia e protezione secondo ultima versione	22/10/01	GL	
N.rev	Nota sulla revisione	Data	Signatura	Controllo

Rif.	Quantità	Titolo/Nome, designazione, materiale, dimensione, etc.			N. articolo/Riferimento	
Progettato da	Controllato da	Approvato da - data	Nome file	Data	30-10-98	Scala 1:1.5
			Titolo/Nome VALVOLA DI SICUREZZA - SOUPAPE DE SECURITE - SAFETY VALVE TIPO-TYPE VS100NCP			
Riproduzione vietata			Non misurare le quote dal disegno		Numero disegno 10.100.10	Modifica A
						Foglio

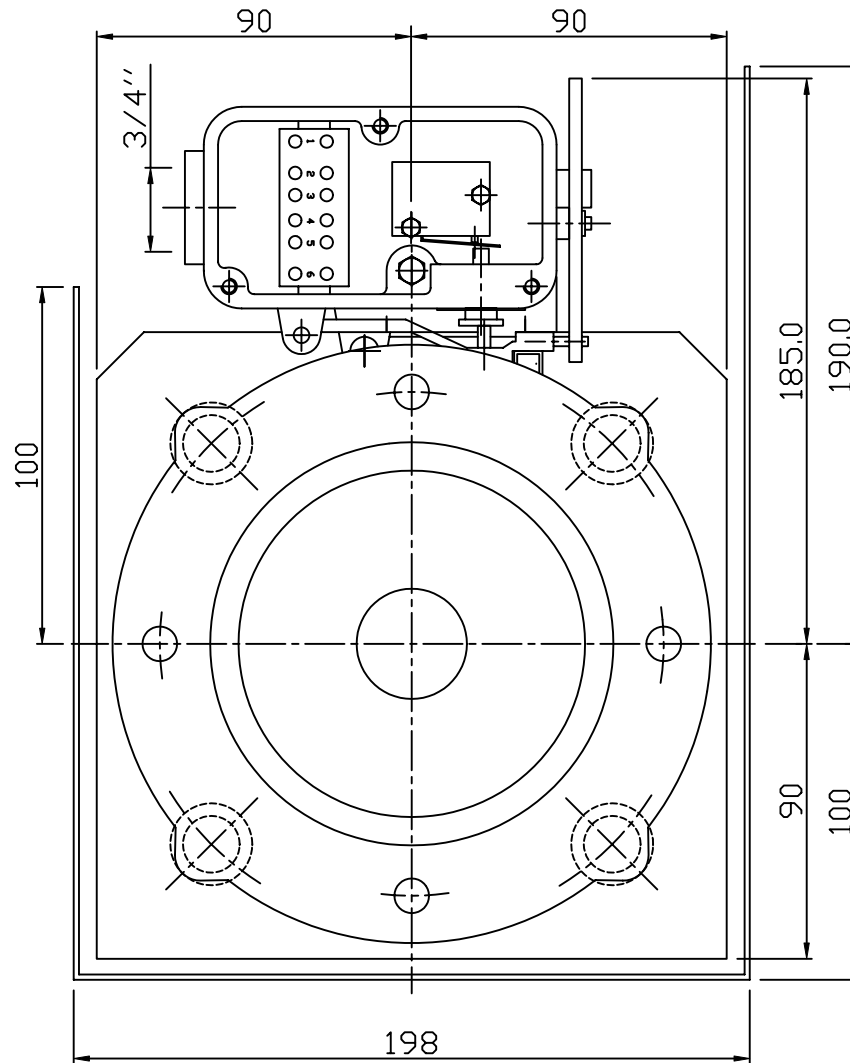
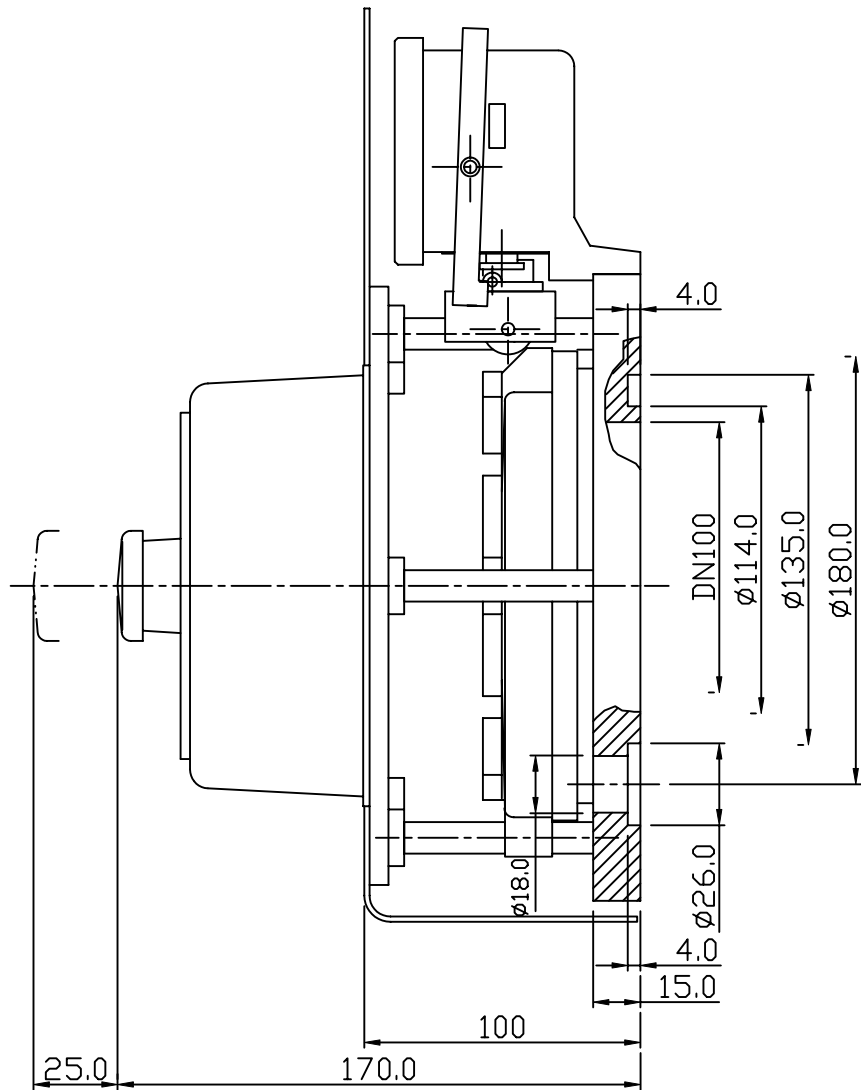

A	Aggiornato dimensioni flangia e protezione secondo ultima versione	22/10/01	GL	
N.rev	Nota sulla revisione	Data	Signatura	Controllo

Rif.	Quantità	Titolo/Nome, designazione, materiale, dimensione, etc.			N. articolo/Riferimento	
Progettato da	Controllato da	Approvato da - data	Nome file	Data	30-10-98	Scala 1:1.5
				Titolo/Nome VALVOLA DI SICUREZZA - SOUPAPE DE SECURITE - SAFETY VALVE TIPO-TYPE VS100NK		
				Numero disegno	10,100,90	Modifico
Riproduzione vietata		Non misurare le quote dal disegno				

Sez.A-A

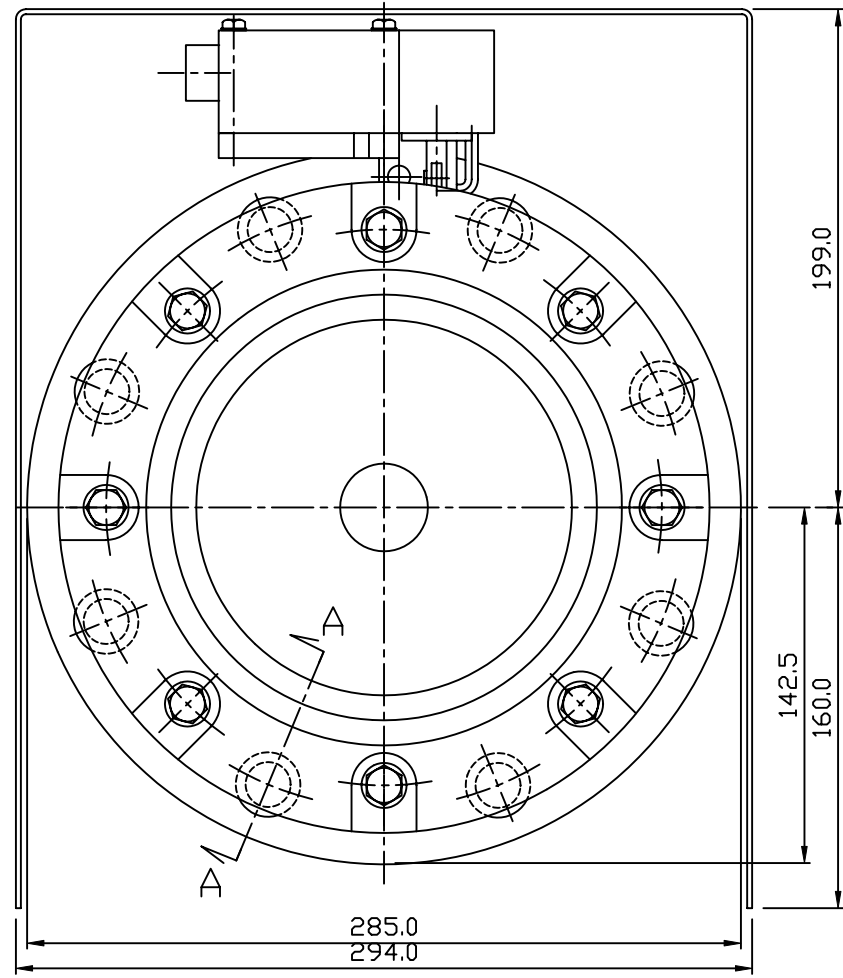
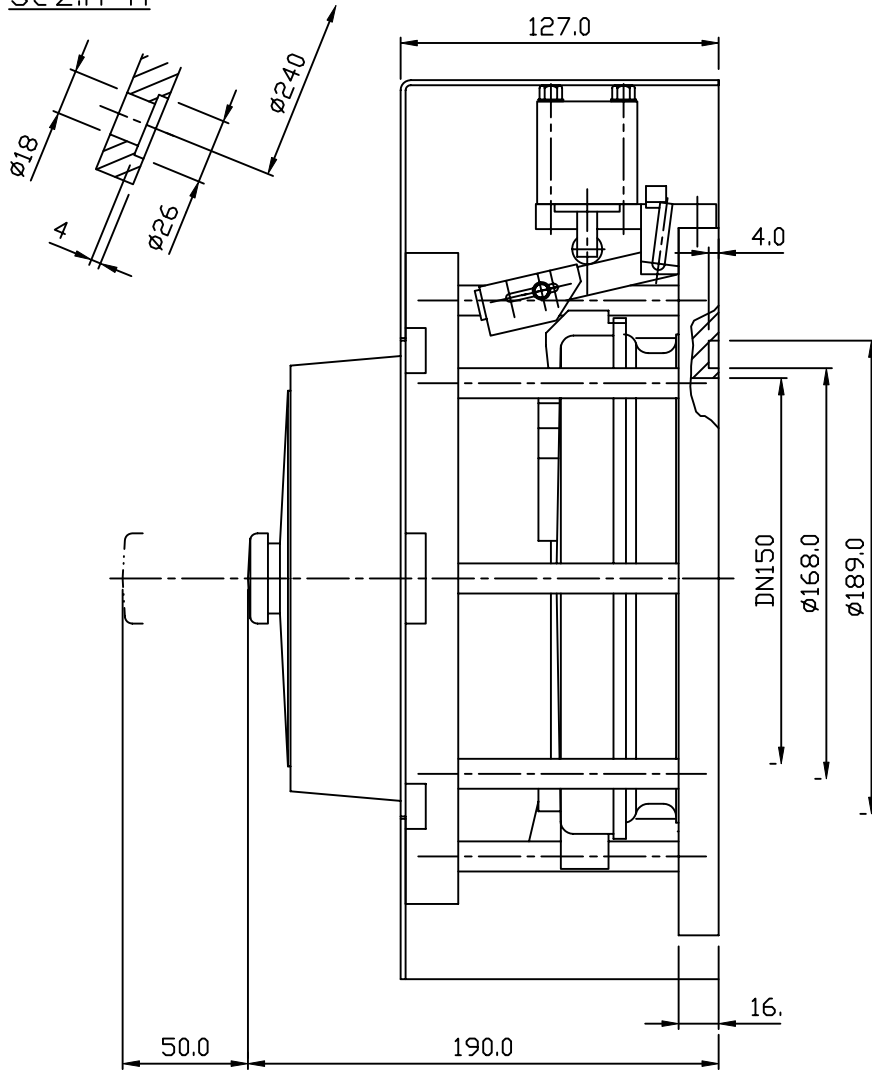

A	Aggiunta Sez.A-A ed evidenziato fori fissaggio a cassa	20-05-99	GL	
N.rev	Nota sulla revisione	Data	Signatura	Controllo

Rif.	Quantità	Titolo/Nome, designazione, materiale, dimensione, etc.			N. articolo/Riferimento
Progettato da	Controllato da	Approvato da - data	Nome file	Data	Scala //
				Titolo/Nome VALVOLA DI SICUREZZA Tipo - Type SAFETY VALVE VS150NCP SOUPEPE DE SECURITE	
Numero disegno				Modifica	Foglio
10.150.10				A	
Riproduzione vietata		Non misurate le quote dal disegno			

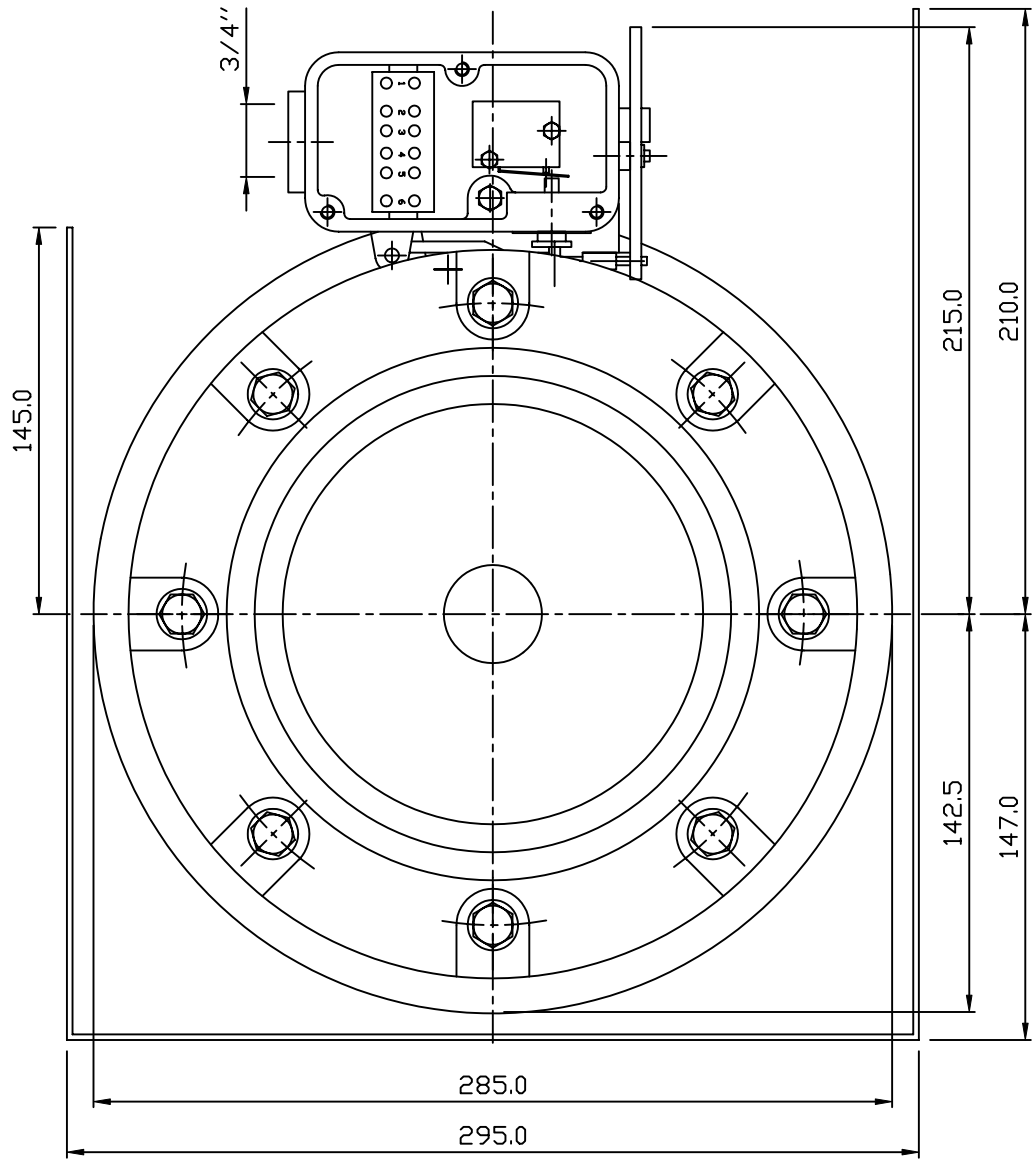
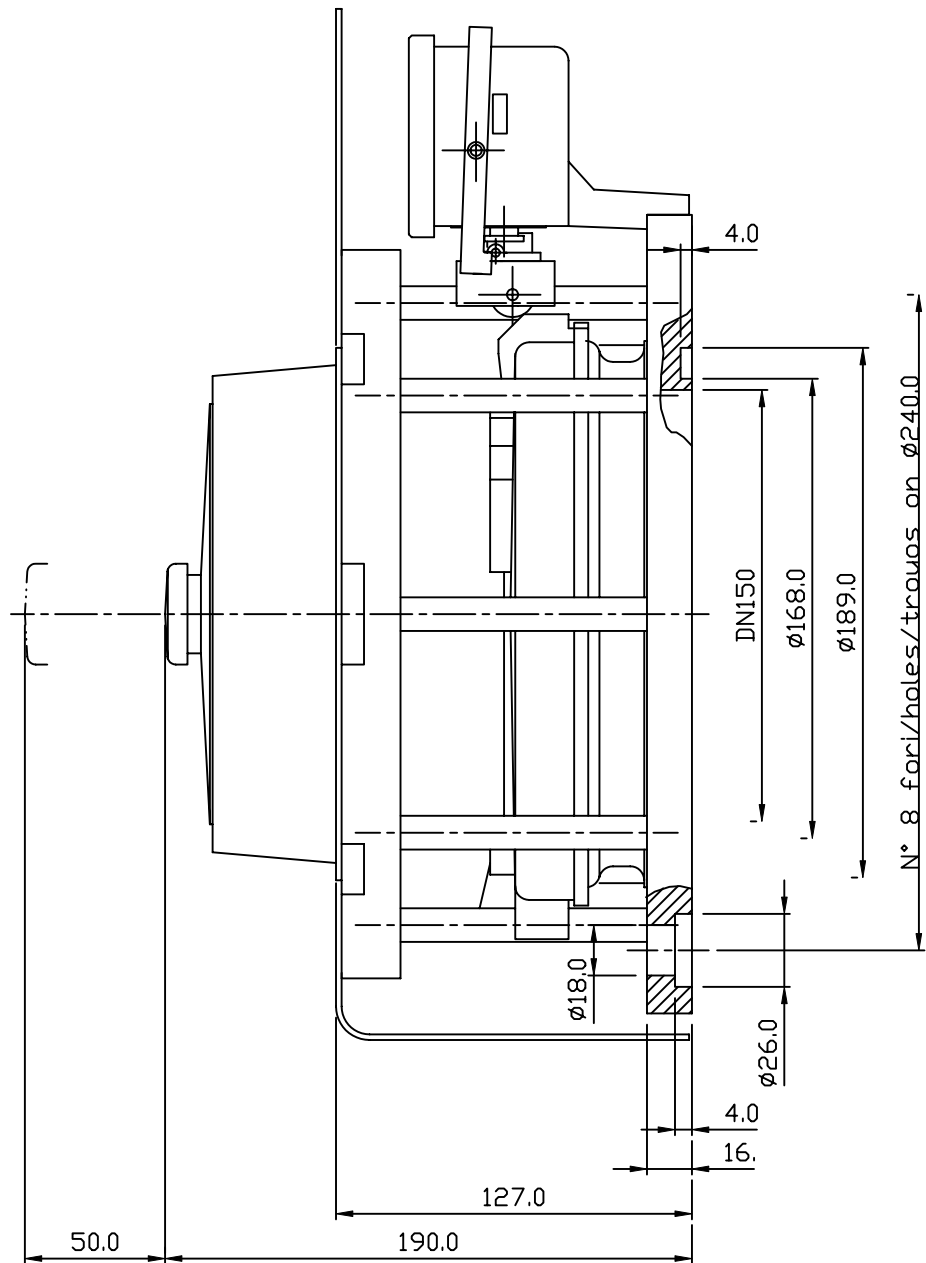

A	Aggiunta indicazione numero fori di fissaggio flangia - Modificata denominazione tipo	11-10-2001	GG	
N.rev	Nota sulla revisione	Data	Signatura	Controllo

Rif.	Quantità	Titolo/Nome, designazione, materiale, dimensione, etc.			N. articolo/Riferimento	
Progettato da	Controllato da	Approvato da - data	Nome file	Data	Scala	
 ETI ELETTRINDUSTRIA S.p.A. 20032 CORMANO ITALY			Titolo/Nome VALVOLA DI SICUREZZA - SOUPAPE DE SECURITA - SAFETY VALVE TIPO-TYPE VS 150 NKP			
			Numero disegno	10.150.90	Modifica	A
Foglio						
Riproduzione vietata		Non misurare le quote dal disegno				

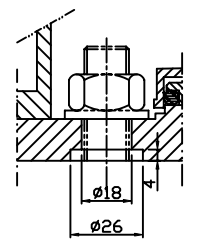
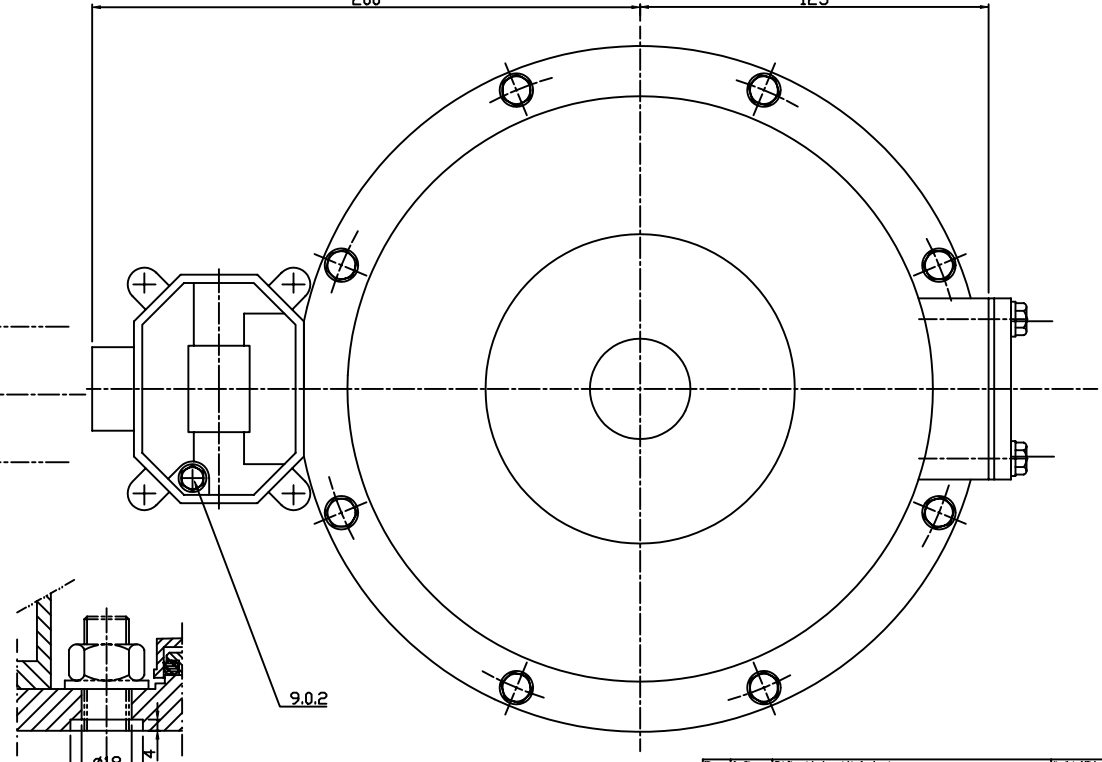
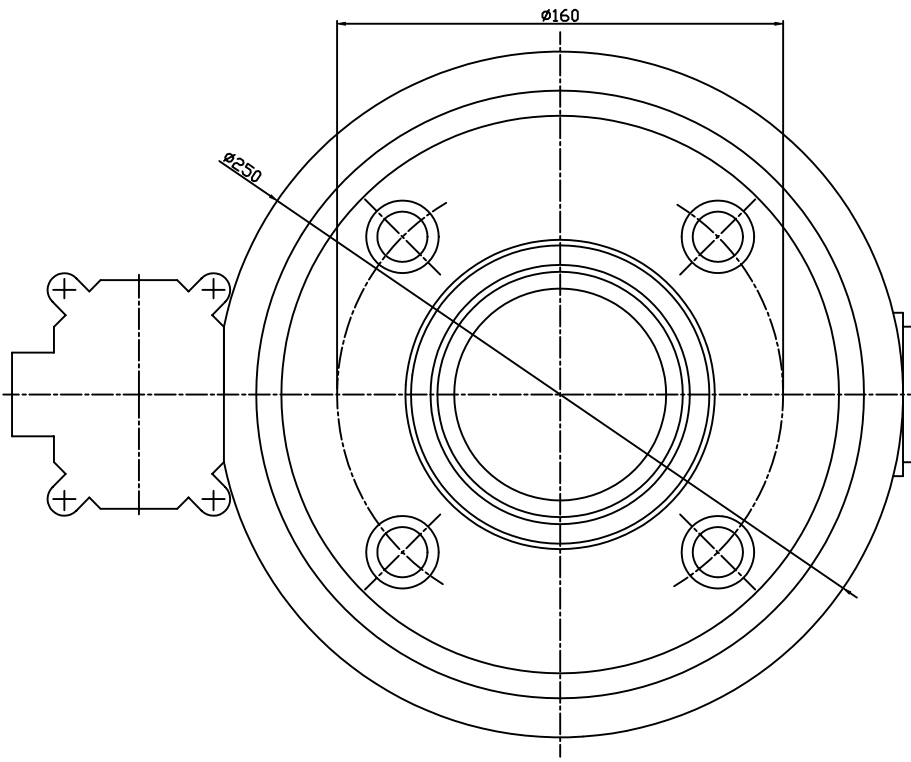
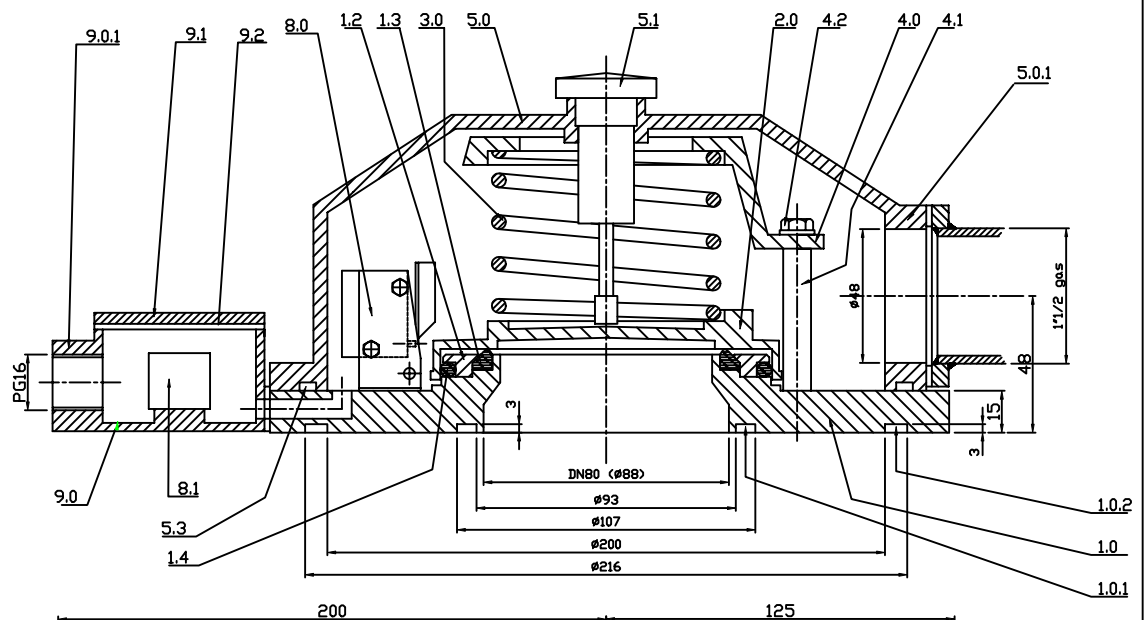
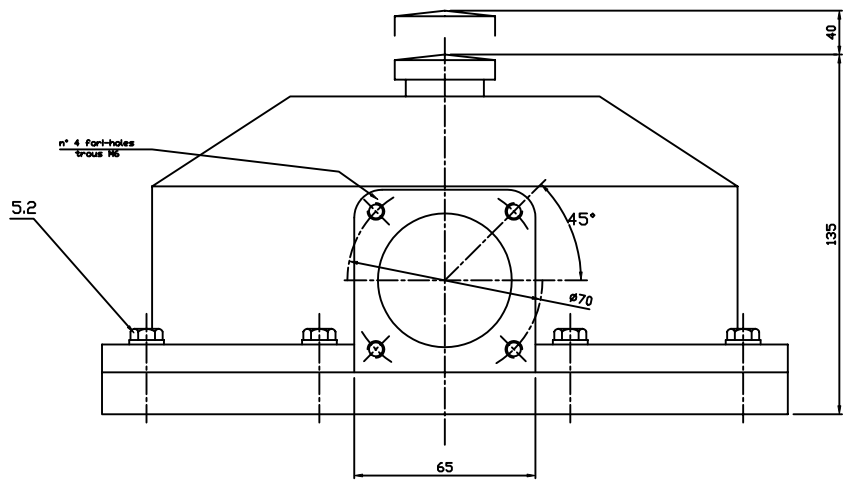

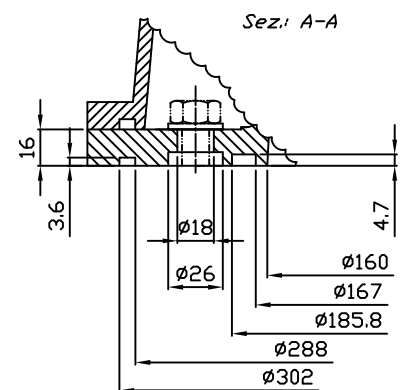
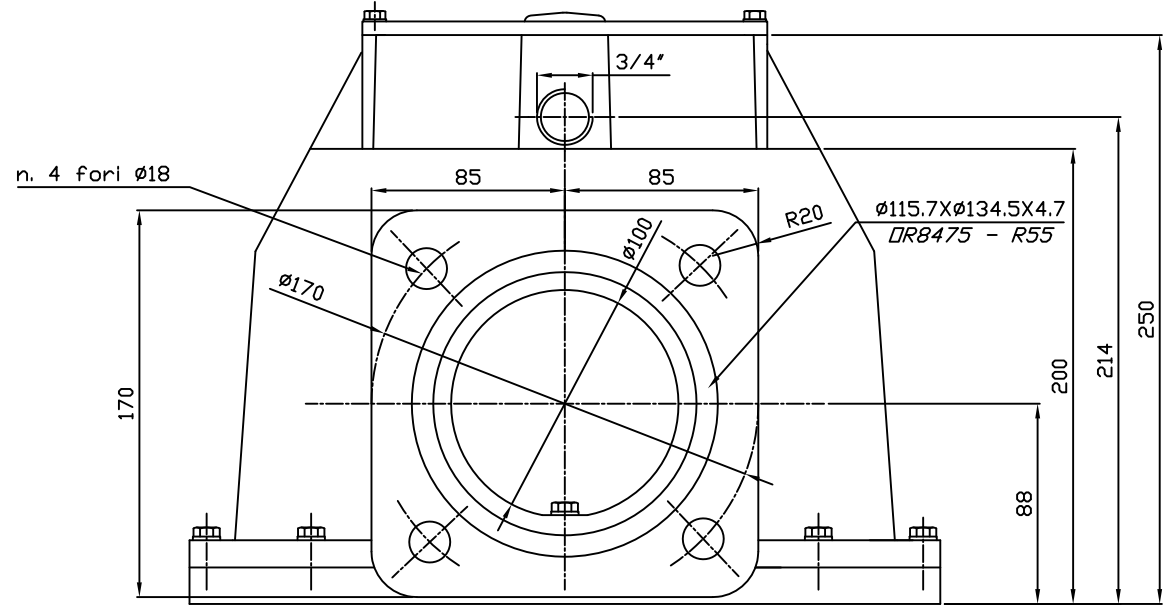
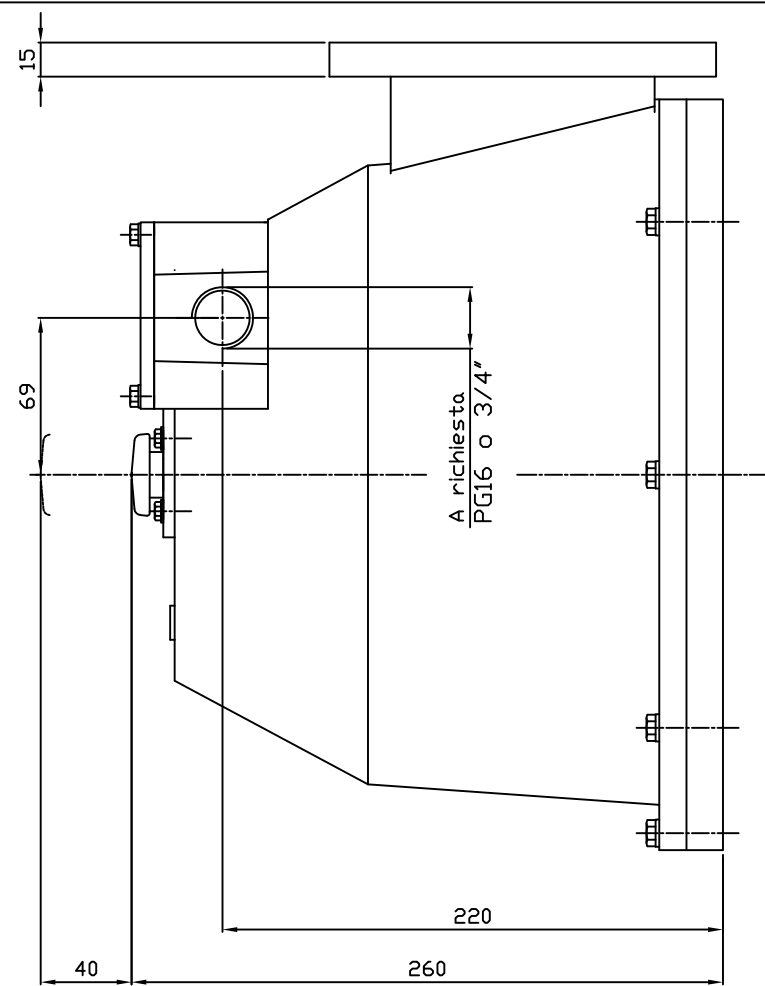
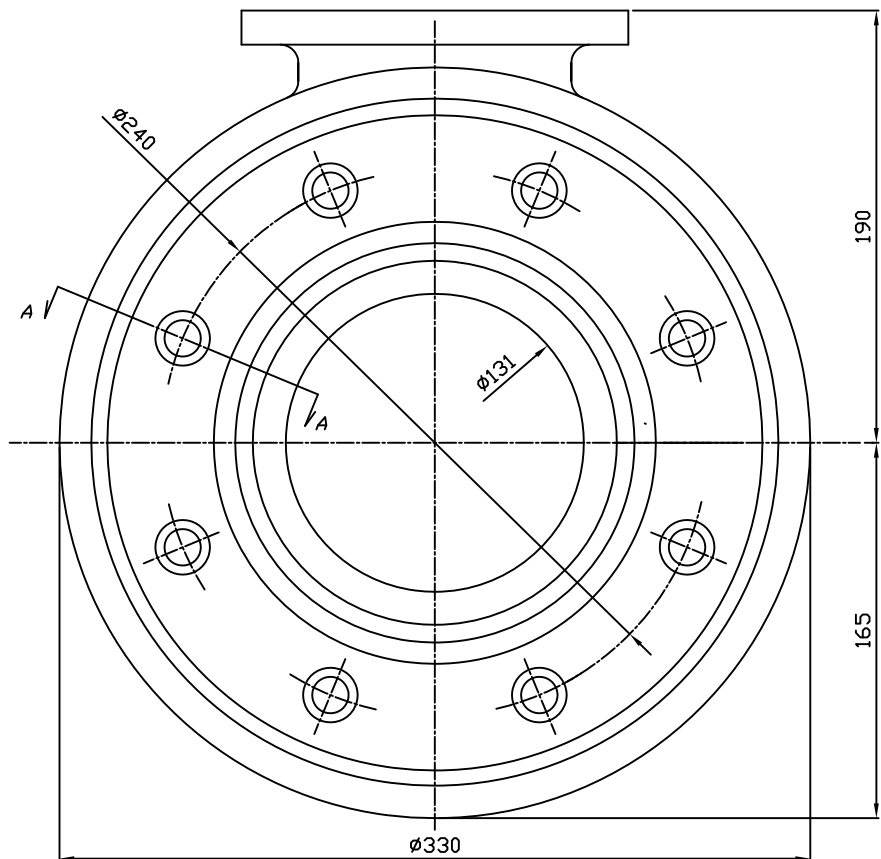

Dettaglio fori fissaggio - Detail mounting holes
 Détail trous de fixation - N° 4

Rev.	Descr.	Modificazioni, sostituzioni, eliminazioni, ecc.	Ed. autor. / Edizione
01	01		24/10/00
		Valvola di sovrappressione Pressure relief valve Soupape de sécurité	Tipo - Type VST 080 K
10.080.70			

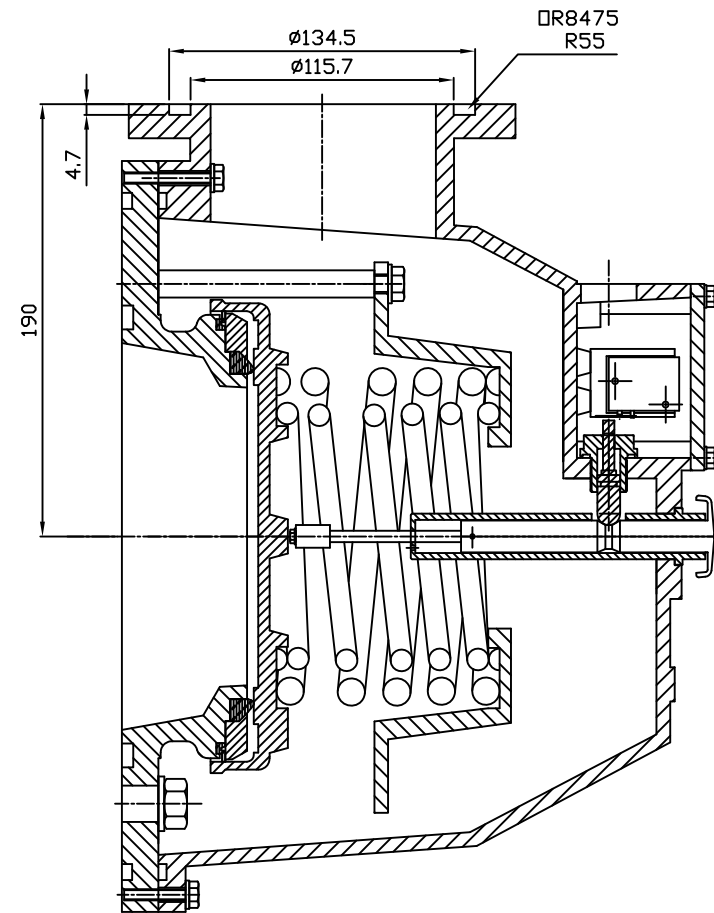
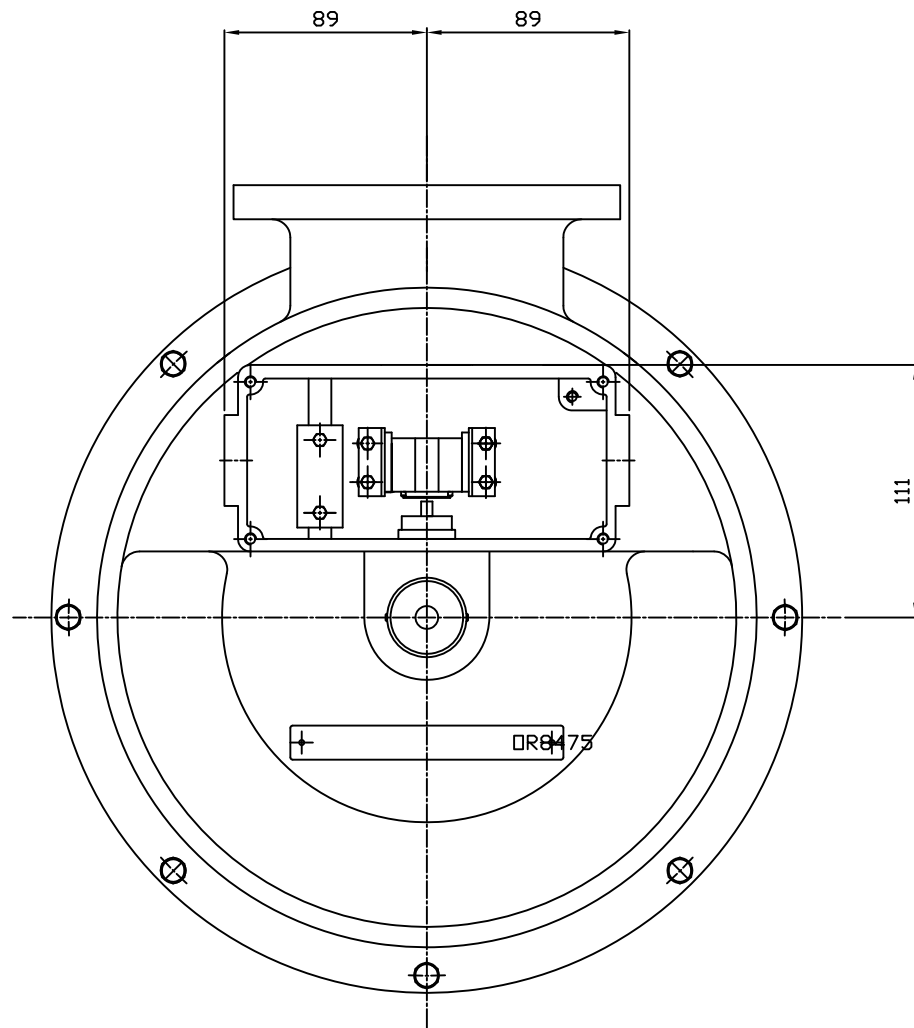

ELETTRINDUSTRIA SRL		Valvola di sicurezza - Pressure relief valve	
20032 CORMANO ITALY		tipo type VST 150	
10.T15.80			



Rif.	Quantità	Titolo/Nome, designazione, materiale, dimensione, etc.			N. articolo / Riferimento	
Progettato da	Controllato da	Approvato da - data	Nome file	Data	20/04/09	Scala
 ELETTRINDUSTRIA SRL 20032 CORMANO ITALY			Valvola di sicurezza - Pressure relief valve tipo type <i>VSQT 150</i>			Numero disegno
			Numero disegno <i>10.Q15.85</i>		Modifica	Foglio